

TAC Xenta® 401:C

Controller, Freely Programmable

TAC Xenta 401:C belongs to a family of freely programmable controllers, with communication features, designed for heating and air handling systems.

A TAC Xenta 401:C holds full HVAC functionality including control loops, curves, time control, alarm handling etc. The controller does not have any inputs or outputs. Instead, required I/O modules from the TAC Xenta 400 series are used.

Up to 15 I/O modules can be connected to the TAC Xenta 401:C. The controller is designed for cabinet mounting.

With TAC Menta programming tool, a TAC Xenta controller is simple to program and place into operation.

The controller communicates on a LonTalk TP/FT-10 network via a twisted-pair, unpolarized cable. It is able to operate both as a stand-alone unit and as part of a system.

The controller can be removed/inserted from/to the terminal part without disconnecting the power supply. When adding or replacing a controller it's also possible to pre-configure it in order to achieve Plug and Play functionality without any on-site configurations.

TAC Xenta 401:C can be connected to a modem or the TAC Vista Building Management System.

For local use, the TAC Xenta OP (Operator Panel) can be connected. The operator panel has a display and push buttons for navigating and altering settings. The operator panel can be snapped onto the TAC Xenta controller unit, mounted on the front of the cabinet, or used as a portable terminal.

TECHNICAL DATA

Supply voltage 24 V AC $\pm 20\%$, 50/60 Hz or 19–40 V DC
 Power consumption max. 2 W
 Transformer sizing 2 VA

Ambient Temperature

Storage $-20\text{ }^{\circ}\text{C}$ to $+50\text{ }^{\circ}\text{C}$ ($-4\text{ }^{\circ}\text{F}$ to $+122\text{ }^{\circ}\text{F}$)
 Operation $\pm 0\text{ }^{\circ}\text{C}$ to $+50\text{ }^{\circ}\text{C}$ ($+32\text{ }^{\circ}\text{F}$ to $+122\text{ }^{\circ}\text{F}$)
 Humidity max. 90% RH non-condensing

Mechanical

Enclosure ABS/PC
 Enclosure rating IP 20
 Flammability class, materials UL 94 V-0
 Dimensions see Fig. 1
 Weight 0.5 kg (1.2 lb)

CPU

CPU 32 bit, 12.28 MHz, 2 MB flash memory, 128 kB SRAM

Real Time Clock

Accuracy at $+25\text{ }^{\circ}\text{C}$ ($77\text{ }^{\circ}\text{F}$) ± 12 minutes per year
 Power outage protection 72 h

Communication

TAC Menta; modem 9600 bps, RS-232, RJ-45
 TAC Vista TP/FT-10, screw terminal
 (also for application program download, from v 3.1)
 TAC Xenta OP TP/FT-10, modular jack

LonMark Standard

Interoperability LonMark Interop. Guidelines v 3.0
 Application LonMark Functional Profile: Plant Controller

Agency Compliances

Emission C-Tick; EN 61000-6-3; FCC Part 15, Subpart B, Class B
 Immunity EN 61000-6-1

Safety

CE EN 61010-1
 UL 916 C-UL US Listed

Part Numbers

Electronics part TAC Xenta 401:C 0-073-0104
 Terminal part TAC Xenta 400 0-073-0902
 Operator panel TAC Xenta OP 0-073-0907
 TAC Xenta: Programming Serial Kit 0-073-0920

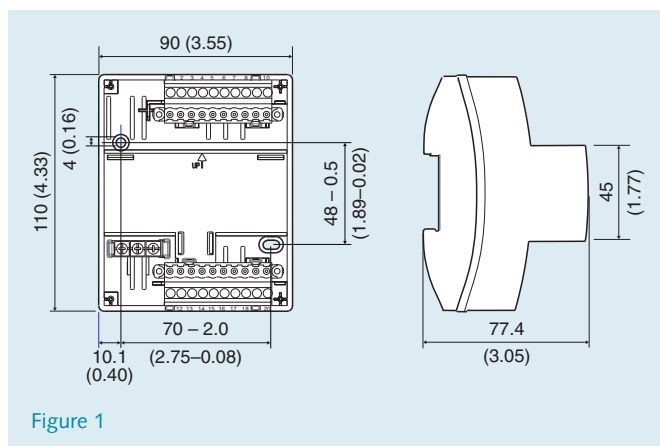

Figure 1

DESIGN

The TAC Xenta 401:C controller has been designed as a general purpose controller. It is normally mounted in a cabinet, with several controllers collected per floor or per building. Its I/O modules can be mounted in close proximity to the controlled equipment, thereby minimizing the wiring required.

TAC Xenta 401:C is microprocessor based. It consists of a terminal and electronics mounted together (Fig. 2).

TAC Xenta 401:C can, via its I/O modules, be interfaced with a wide variety of field sensors/transducers and controlled devices.

Local Operator Panel

The TAC Xenta OP (Operator Panel) is a small operator panel which can be connected to the unit through its enclosure. The operator can read the point status, perform manual override, read measured values, alter set points etc., from the operator panel.

The functions are selected from menus. Access to the unit is enabled by using an access code. It is possible to access other TAC Xenta units on the same network.

Power Outage Protection

With non-volatile (flash) memory, the unit will start up with user settings and work normally after a power outage.

Real Time Clock

The real time clock provides data such as year, month, date, day, hour, minute and second. A built-in capacitor maintains operation of the clock for at least 72 hours in the event of a power outage.

Daylight Saving Time:

European, Australian or USA/Canada

Once set, Daylight Saving Time (DST) is fully automatic. The change-over date and the number of hours to change are programmable. This function can also be disabled.

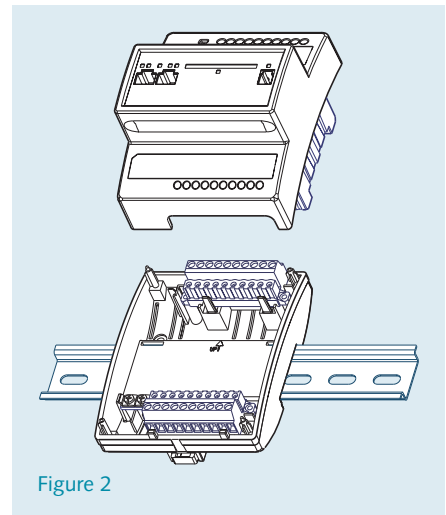

Figure 2

LonWorks SNVT Support

The use of Standard Network Variable Types (SNVT), in accordance with the Echelon specification, makes it possible to communicate with nodes made by other manufacturers.

I/O MODULES

TAC Xenta 401:C has no inputs or outputs by itself. Instead, the required number of I/O modules from the TAC Xenta 400 series are used.

The TAC Xenta 401:C can have up to 15 I/O modules.

The table gives an overview of the different numbers of inputs and outputs.

DI, DO: Digital input, output

UI: Universal input

TI: Thermistor input

AO: Analog output

The Xenta 4x2 modules have manual overrides for the DO or AO, and/or DI status indication, where applicable.

I/O Module	DI	DO	UI	TI	AO
TAC Xenta 411/412	10	–	–	–	–
TAC Xenta 421/422	4	5	–	–	–
TAC Xenta 421A/422A ¹	–	5	4 ²	–	–
TAC Xenta 451/452 ¹	–	–	4 ³	4	2
TAC Xenta 451A/452A ¹	–	–	8 ²	–	2
TAC Xenta 471	–	–	8 ⁴	–	–
TAC Xenta 491/492	–	–	–	–	8

1 Status indication only when the corresponding universal inputs (UI) are used as digital inputs (DI).

2 1.8/10 kΩ TI, 0–10 V DC, 0–20 mA, DI

3 1.8 kΩ TI, 0–10 V DC, DI

4 0–10 V DC, 0–20 mA

SOFTWARE FEATURES

With the assistance of TAC Menta, a graphical programming tool using Functional Block Diagrams (FBDs), the TAC Xenta 401:C may be easily adapted to different control and monitoring tasks.

The basic software includes pre-programmed routines for:

- reading of digital inputs (alarms, pulse counting, interlocks)
- reading of universal inputs (individually selectable as analog or digital)
- control of digital outputs
- control of analog outputs
- on and off delays
- pulse counting (digital inputs only)
- alarm handling; alarm conditions may be detected via the digital or analog inputs

- equipment run time totals on selected objects
- programs for optimum start/stop
- control characteristic curves
- PID control loops (loops may be connected in cascade)
- trend logging for up to 50 channels
- local level operator interface via TAC Xenta OP (Operator Panel)
- network communication according to the LonTalk protocol
- communication with the TAC Vista Building Management System via modem
- connection to 15 I/O modules

The basic software is adapted to the current application by connecting pre-programmed functional blocks and by adjusting the relevant parameters. These connections and parameters are stored in non-volatile memory.

The parameters may be changed during ongoing operation either from the TAC Vista Building Management System or locally from the TAC Xenta OP (Operator Panel).

COMMUNICATION

LonWorks Connection

TAC Xenta controllers communicate with each other using a common network, LonWorks TP/FT-10.78 kbps.

Associated I/O modules also connect to the network. An I/O module can only be associated with one controller.

TAC Vista Building Management System

When connected to a TAC Vista Building Management System, the operating conditions of the fans, pumps, heat exchangers, etc. can be monitored in color graphics or printed reports.

Temperatures and alarms can be read, while setpoints, time settings may be altered as required.

TAC Xenta controllers can be reached from TAC Vista in one of the following ways:

- 1 Any controller in the network via a PCLTA card or via a TAC Xenta 511 or 911 acting as an LTA.
- 2 A specific controller via the RS-232 connection. (All versions starting with v 3.x.)
- 3 Any base unit in the network via TAC Xenta 901 LonTalk adapter (and an optional modem connection), with the added possibility for the base unit to initiate the dial-up (the latter only for v 3.2).

Starting with v 3.1, application programs generated in TAC Menta may be downloaded from TAC Vista via the network.

TAC Xenta Operator Panel Port

The TAC Xenta OP (Operator Panel) is also connected to the network and can thus act as an operator panel for other units in the network. The connection is made via the modular jack on the front of the controller or directly, using the network cable.

RS-232 Port

The TAC Xenta 401:C controller has an RS-232 port. This port is intended for connection to a PC with the TAC Menta programming tool for loading and commissioning the application programs.

The port can also be used for connection via modem between TAC Vista and specific TAC Xenta 401:C units (see 2 under "TAC Vista Building Management System" above).

SYSTEM CONFIGURATIONS

The TAC Xenta 401:C controller can be used in different configurations;

- as a stand-alone unit (together with the required I/O modules)
- as a controller (with operator panel) in a small network, with extra I/O modules as required
- as a controller (with operator panel) and other equipment in a full network with suitable adapters, possibly connected to a TAC Vista Building Management System

Fig. 3 shows an example of a networked TAC Xenta configuration.

Sensors and actuators on the field level are mostly connected to the conventional inputs and outputs of the I/O-modules.

Some external units, however, may connect directly to the network to communicate input/output data, using Standard Network Variables Types (SNVTs).

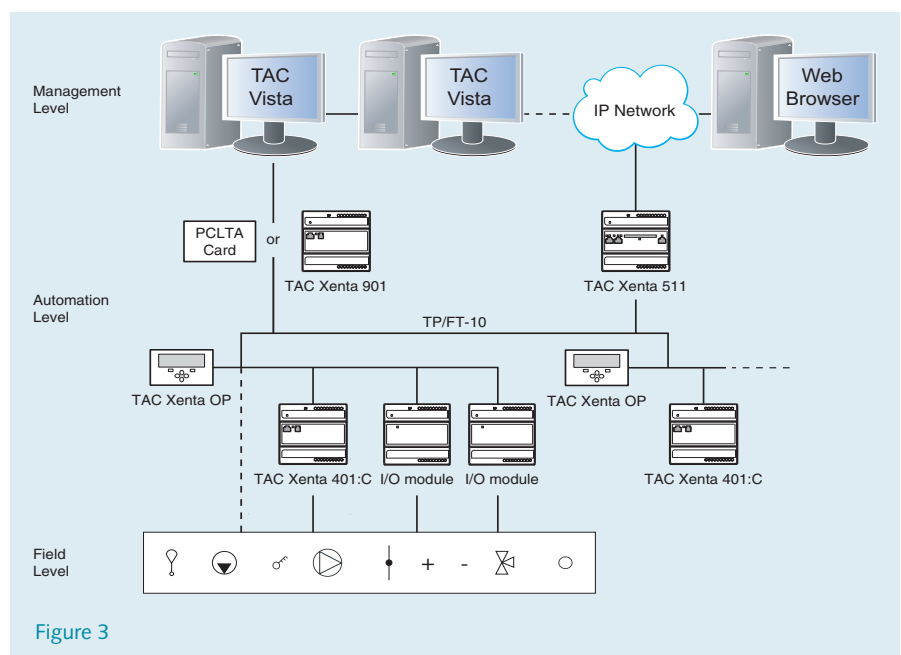

Figure 3

TAC XENTA NETWORK AND UNIT PERFORMANCE

Per TAC Vista Server

No. of base units	400
No. of I/O modules	200
No. of operator panels	100
No. of TAC Xenta groups	30
No. of base units per group	30

Per TAC Xenta 401:C Unit

No. of I/O modules	15
No. of STR350/351 (non-SNVT mode)	0
No. of subscriptions*	
In	max. 125
Out	max. 125

Trend Logging in TAC Xenta 401:C (from v 3.3)

Channels	1–50
Interval	10 s – 530 weeks
Total logging cap.	approx. 7,000 floating point numbers or approx. 15,000 integers or approx. 110,000 digital values
Optimized storage	Yes

Application Size

Program and data	max. approx. 234 kB
Parameters	max. approx. 234 kB

* Subscriptions can utilize Standard Network Variable Types (SNVTs) or TAC Network Variables (TACNVs). These can be combined if the following restrictions are observed: the sum of the TACNV subscriptions and the number of SNVT members (no. of values in structured SNVTs) does not exceed the stated figures.

MOUNTING

The TAC Xenta 401:C is cabinet mounted on a TS 35 mm Norm rail EN 50 022.

The controller unit consists of two parts; a terminal part with screw terminals, and electronics with the circuit boards.

To simplify installation, the terminal can be pre-mounted in the cabinet (see Fig. 2).

The operator panel is either mounted onto the controller on the snap-in connector, or flush-mounted in the cabinet

front. It can also be used as a portable, hand held panel.

If the TAC Xenta 401:C controller is wall mounted, a wide range of standardized boxes are available.

CABLES

G and G0

Min. area 0.75–1.5 mm² (19–16 AWG).

Cable with modular jack for RS-232 serial communication port: Max. 10 m (32 ft).

C1 and C2

TP/FT-10 allows the user to wire the control devices with virtually no topology restrictions. The max. wire distance in one segment depends on the type of wire and the topology, see the table below.

For more details, see the TAC Xenta 280/300/401 Handbook (part no. 0-004-7768).

Cable	Max. bus length, doubly terminated bus topology m (ft)	Max. node-to-node distance, singly terminated free topology m (ft)	Max. length singly terminated free topology m (ft)
Belden 85102, single twisted pair	2,700 (9,000)	500 (1,600)	500 (1,600)
Belden 8471, single twisted pair	2,700 (9,000)	400 (1,300)	500 (1,600)
UL Level IV 22AWG, twisted pair	1,400 (4,600)	400 (1,300)	500 (1,600)
Connect-Air 22AWG, one or two pairs	1,400 (4,600)	400 (1,300)	500 (1,600)
Siemens J-Y(st)Y 2x2x0.8 4-wire helical twist, solid, shielded	900 (3,000)	320 (1,000)	500 (1,600)
TIA568A Cat. 5 24AWG, twisted pair	900 (3,000)	250 (820)	450 (1,500)

INSTALLATION

There is a label on the front of the controller with both the numbers and the names of the terminals (1 C1, 2 C2 and so on). The numbers are also shown in the plastic of the terminal part.

TAX Xenta Operator Panel

The TAC Xenta operator panel can easily be connected to the network by means of the modular socket on the front of the controller.

LED Indicator

An LED indicator on the electronic unit of the TAC Xenta 401:C indicates when the application program is running.

Service Pin

To simplify network commissioning, there is a service pin on the electronic unit which, when pressed, identifies the unit on the network.

Terminal Connections

Term. No.	Term. Name	Description
1	G	24 V AC (or DC+)
2	G0	Ground
3	C1	LonWorks TP/FT-10
4	C2	LonWorks TP/FT-10

MAINTENANCE

The only care needed is to keep the controller dry and to clean it externally with a dry cloth when needed.

Copyright © 2006, TAC

All brand names, trademarks and registered trademarks are the property of their respective owners. Information contained within this document is subject to change without notice. All rights reserved.

0-003-2709-2



Europe / Headquarters
Malmö, Sweden
+46 40 38 68 50

Americas
Dallas, TX
+1 972-323-1111

Asia-Pacific
Sydney, Australia
+61 2 9700 1555

www.tac.com

