

TAC Xenta[®]



TAC Xenta 103-A Handbook

TAC Xenta[®]

TAC Xenta 103-A
Handbook



Copyright © 2004 TAC AB. All rights reserved.

This document, as well as the product it refers to, is only intended for licensed users. TAC AB owns the copyright of this document and reserves the right to make changes, additions or deletions. TAC AB assumes no responsibility for possible mistakes or errors that might appear in this document.

Do not use the product for other purposes than those indicated in this document.

Only licensed users of the product and the document are permitted to use the document or any information therein. Distribution, disclosure, copying, storing or use of the product, the information or the illustrations in the document on the part of non-licensed users, in electronic or mechanical form, as a recording or by other means, including photo copying or information storage and retrieval systems, without the express written permission of TAC AB, will be regarded as a violation of copyright laws and is strictly prohibited.

Trademarks and registered trademarks are the property of their respective owners. Microsoft® and Windows® are registered trademarks of The Microsoft Corporation.

Trademarks and registered trademarks are the property of their respective owners.

TAC Vista®, TAC Menta®, TAC Xenta® and TAC I-talk® are registered trademarks of TAC AB.

Contents

1	Documentation and Terminology	7
1.1	Documentation	7
1.2	Terminology	8
2	Zone Controller Xenta 103-A	9
2.1	General	9
2.2	Wall Modules	11
2.2.1	STR350/351	11
2.2.2	STR150	12
2.2.3	STR100-104	13
2.2.4	Wall Module Configuration	14
2.3	Applications	15
2.3.1	General	15
2.3.2	The Zone Controller TAC Xenta 103-A	15
3	Installation	17
3.1	Mechanical Installation	17
3.1.1	Fitting	17
3.2	Electrical Installation	18
3.2.1	General	18
3.2.2	Wiring of TAC Xenta 103-A	21
3.3	Commissioning	22
3.3.1	General	22
3.3.2	Node Status	22
3.3.3	Configuration Parameters (nci's)	23
3.3.4	Network Installation	23
3.3.5	Network Variable Binding	24
3.3.6	Function Test	24
4	Configuration Parameters	25
4.1	Basic Parameters	26
4.2	Other Configuration Parameters	27
5	Functional Description	31
5.1	General	31
5.2	The Controller's Basic Functions	31
5.2.1	Operation Modes	31
5.2.2	Forcing the Controller	33
5.2.3	Measuring Zone Temperature	34
5.2.4	Setpoint Calculation	34
5.2.5	Control Sequence	37
5.3	More About Functions	38

5.3.1	Heating Control	38
5.3.2	Cooling Control (Chilled Ceiling).....	38
5.3.3	Cooling Controller (air).....	39
5.3.4	Air Quality Control.....	40
5.3.5	Window Contact.....	41
5.3.6	Occupancy Sensor	41
5.3.7	Minimum Value for Heating Valve.....	42
5.3.8	Alarm.....	43
5.3.9	Frost Protection	44
5.3.10	Master/slave Operation.....	44
6	Trouble-shooting	47
6.1	General	47
6.2	Inputs and Outputs (nvi/nvo's).....	47
6.3	Trouble-shooting Guide.....	48
7	Technical Data	49
7.1	Technical Data.....	49
7.2	Dimensions	51
8	Communication	53
8.1	General	53
8.2	Default Settings and Power on	53
8.3	Monitoring Network Variables, Heartbeat	54
8.4	Not Accepted Values.....	55
8.5	The Node Object.....	55
8.5.1	The Node Object's Inputs (nvi).....	56
8.5.2	The Node Object's Outputs (nvo)	56
8.5.3	The Node Object's Configuration Parameters (nci).....	56
8.6	The Controller Object.....	56
8.6.1	The Controller Object's Inputs (nvi)	59
8.6.2	The Controller Object's Outputs (nvo).....	60
8.6.3	The Controller Object's Configuration Parameters (nci).....	61
 APPENDIX		
A	Setpoint Calculation	65
B	Commissioning Protocol	69
	Index	71

1 Documentation and Terminology

1.1 Documentation

Enclosed Documentation

TAC Xenta 103-A is delivered with an installation instruction in Swedish, English and German.

- Installation instruction, TAC Xenta 103-A, part number 0FL-3873

Other Documentation

There is additional information about TAC Xenta 103-A in the following documents:

- Data sheet for TAC Xenta 103-A, part number 0-003-1636
- Data sheet for ZS 103–ZS 105, part number 0-003-1662.
- Data sheet for STR100–STR107, part number 0-003-2304.
- Data sheet for STR150, part number 0-003-2306.
- Data sheet for STR350/351, part number 0-003-2310.
- TAC Xenta Network Guide, part number 0-004-7461.
- TAC Xenta OP Handbook, part number 0-004-7505.
- TAC Xenta, Zone System Guidelines part number 0-004-7636.

All the above mentioned documents can be found on the internet at www.tac.com or ordered from your nearest TAC service provider.

1.2 Terminology

This handbook contains some abbreviations and terms, which are specific for the zone controller's applications and network communication. The most common terms are explained in Table 1.1, "Terminology"

Table 1.1: Terminology

neuron	communication processor with built-in protocol
node	communication unit on the network
SNVT	Standard Network Variable Type
nvixxx	variable that gets its value from another unit on the network
nvoxxx	variable that is sent to another unit on the network
ncixxx	configuration parameter; variable that gets its value from another unit on the network and keeps it during a power failure
service pin	function that can be used during installation on the network
wink	confirmation that the connection to a controller via the network is working (a LED is lit for appr. 15seconds)
LNS	LonWork [®] Network Services. System tool for installation, configuration and maintenance of LonWorks network

2 Zone Controller Xenta 103-A

2.1 General

The zone controller TAC Xenta 103-A is mainly intended for chilled ceilings in offices and other larger buildings. For chilled ceiling applications, the zone temperature is controlled by modulation of the chilled water flow to ceiling elements, so called cooling baffles, and the hot water flow to radiators.

The Controller's Basic Functions

The controller can handle the following applications:

- Heating and cooling
- Heating only
- Cooling only, air and/or water

More About Functions

Apart from the controller's basic functions, there are a number of other functions for controlling the climate in the zone; these are described in detail in Chapter 5, "Functional Description", on page 31. Additional external functions that can be connected are also described in this chapter, these include window contact sensor and occupancy sensor.

Communication

The controller can work either as a stand-alone unit, without being connected to a network during operation, or as a part of a larger system with several other units such as TAC Xenta 300/400 and other zone controllers in the TAC Xenta family (Fig. 2.1). A detailed description of how units work together in a larger zone system is found in "Zone Systems Guidelines", part number 0-004-7637.

TAC Vista is an excellent tool for reading variables as well as a configuration tool for commissioning and/or operation purposes. When TAC Vista is not part of the system, reading and configuration of variables can be made from the operating panel TAC Xenta OP, version 3.11 or later.

The controller is LonMark[®] approved and communicates on a LonTalk[®] TP/FT-10 network via a twisted-pair, unpolarized cable. If you want to know more about the LonWorks[®] technology, visit www.echel.com or www.lonmark.org.

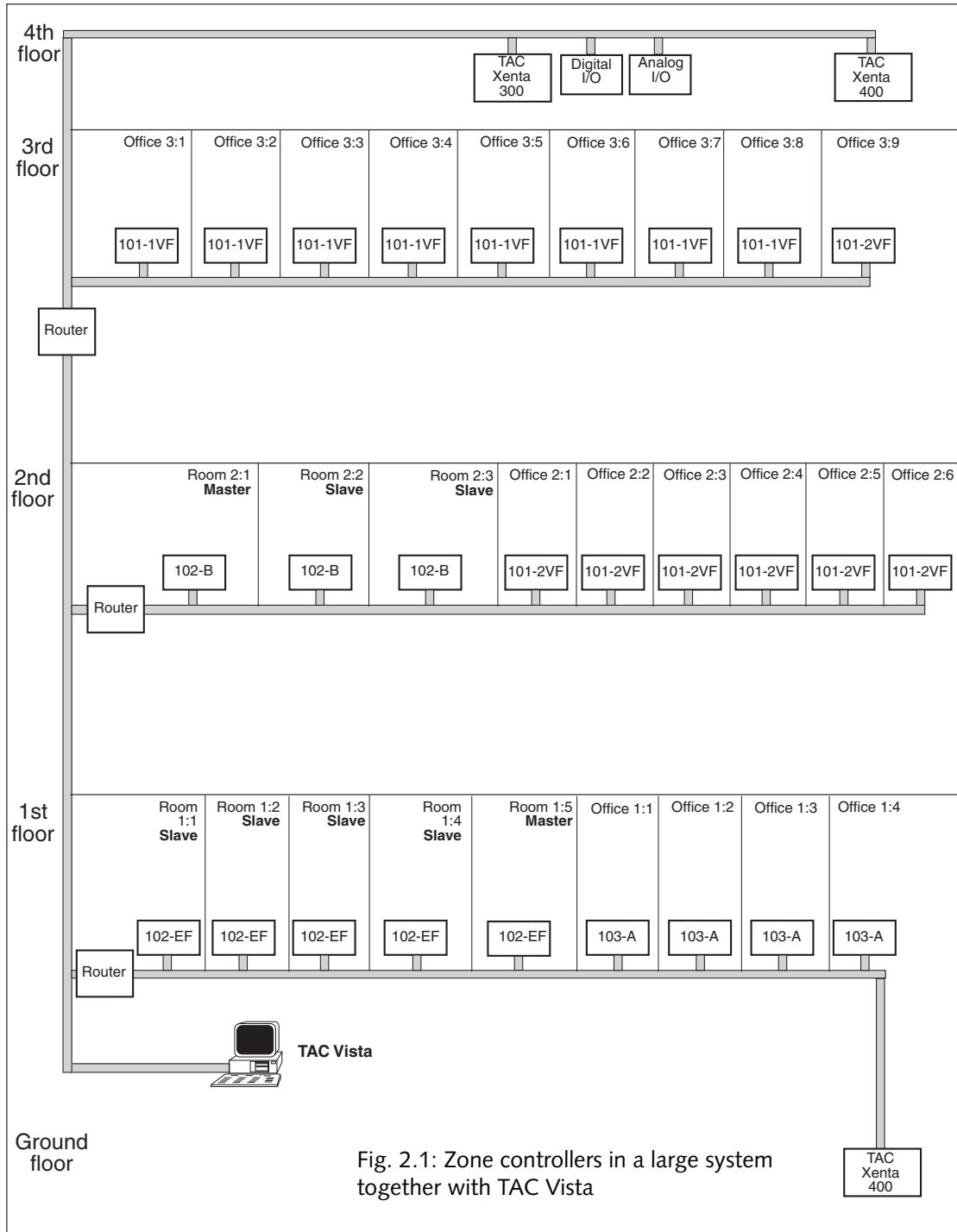

Fig. 2.1: Zone controllers in a large system together with TAC Vista

2.2 Wall Modules

A temperature sensor must be mounted within in the zone to be controlled. In the STR series of wall modules the temperature sensor is combined with various types of user interface. Several STR models can be used with the TAC Xenta 103-A; the choice is determined by the desired functionality and user interface.

- STR350/351. Wall unit with temperature sensor and LCD display. Extensive functionality for zone control. Communicates with the controller over LonWorks.
- STR150. Wall unit with temperature sensor and LCD display. Incorporates the most common functions for zone control. One-way serial communication with the controller.
- STR100-104. Wall module with temperature sensor and controls for the most common zone control functions. STR100-104 signals are hard-wired to TAC Xenta 103-A I/O.

2.2.1 STR350/351

STR350/351 communicates over LonWorks. LonWorks is used for all data exchanges between the room unit and the controller.

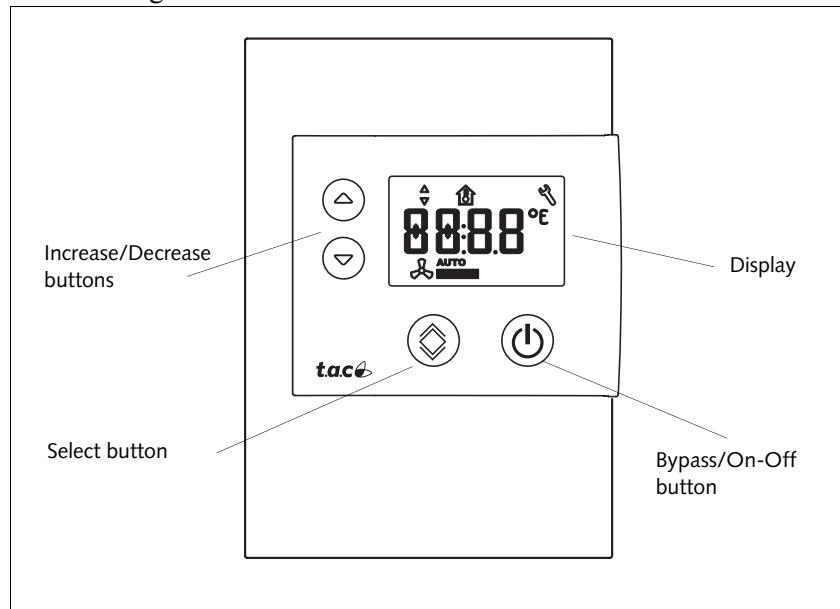

STR350/351 has the following functionality when used with TAC Xenta 103-A:

- **Temperature sensor.** Use either the built in thermistor element or any other temperature sensor connected to the LonWorks network
- **Actual temperature display.** The actual zone temperature can be displayed on the LCD. It can be hidden if preferred.
- **Temperature setpoint display.** The temperature setpoint can be displayed, either as an absolute value or as an offset.

- **Temperature setpoint adjustment.** The temperature setpoint can be adjusted, either as an absolute value or as an offset.
- **Bypass or on/off button.** The bypass function forces the controller to comfort mode for a configurable period of time. The same button can also be used as an on/off button.
- **Mode Indicator.** An On/Off symbol in the LCD indicates the mode of the control.

See STR350/351 configuration and data sheets for more details about the technical characteristics listed above, additional functions and configuration details.

Use the LNS plug-in to configure STR350/351.

2.2.2 STR150

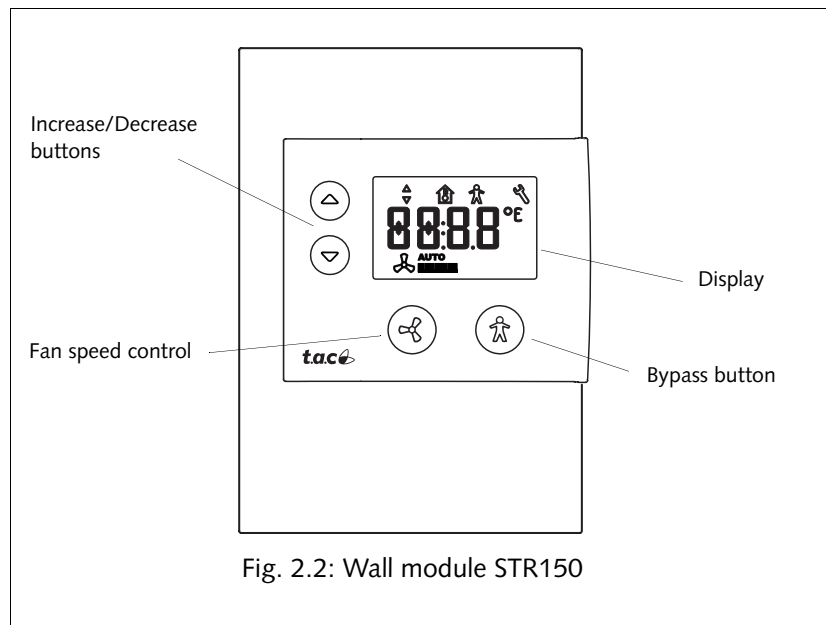

STR150 is connected to TAC Xenta 103-A using two or three wires; the third wire is used if mode indication in the LCD is required. The other two wires are used to send information from the wall unit to the controller:

- **Zone temperature.** The temperature sensed by the thermistor element.
- **Temperature setpoint.** The temperature setpoint is displayed as an absolute temperature, but transmitted as an offset to the configured reference temperature.
- **Bypass button.** The bypass button forces the controller to comfort mode for a fixed period of time (2h).

The third wire is connected to the symbol of a man on the LCD:

- Comfort mode (On) is indicated by a steady symbol

- Economy (Standby) mode is indicated by a flashing symbol.
- If the symbol is not shown (off) the zone is unoccupied.

There is no communication from the controller to the unit. This means that if a setpoint is changed using TAC Vista, the new value cannot be displayed on STR150.

STR150 is configured using the buttons and display on the unit. See STR150 configuration and data sheets for details.

2.2.3 STR100-104

STR100-104 is a series of room units that connect to the I/O terminals of TAC Xenta 103-A. The functionality of the various models are shown in the Table 2.1, “STR100-104 functionality”.

Table 2.1: STR100-104 functionality

Model	Temp Sensor	Mode Indicator	Setpoint Adjustment	Bypass Button
STR100	X			
STR101	X	X		
STR102	X	X	X	
STR103	X	X		X
STR104	X	X	X	X

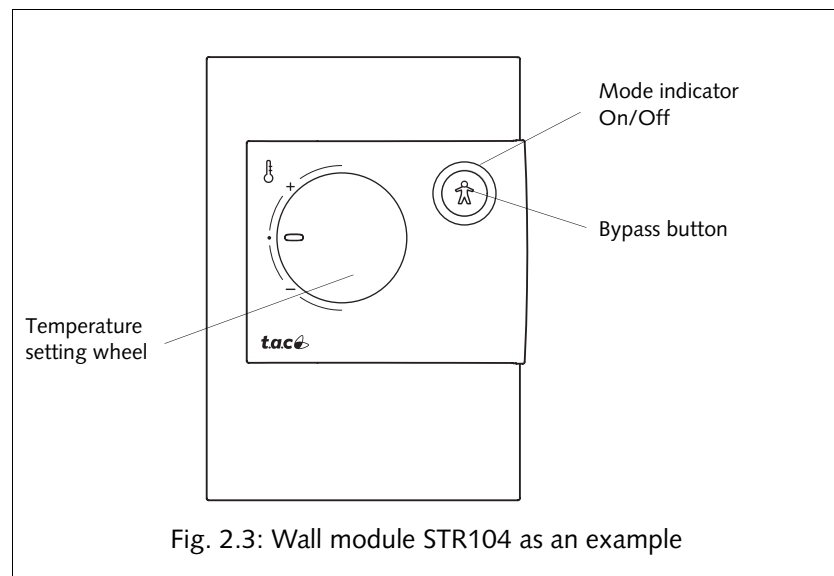

Note! The TAC Xenta OP is normally connected directly to the controller, not the wall module. The TAC Xenta 101-VF has a TAC Xenta OP access connector (type RJ-10) on the controller instead of dedicated terminals for the wall module.

Depending on model the following functionality may be present:

- **Temperature Sensor.** All models have a 1.8Kohms@25°C thermistor element.
- **Temperature Adjustment.** The temperature setpoint can be adjusted. Using the plastic keys on the rear of the core panel the adjustment range can be set.
- **Mode Indicator.** The green LED indicates the control mode:
 - Comfort mode (On) is indicated by a steady green light
 - Economy (Standby) mode is indicated by a flashing green light.
 - If the LED is off the zone is unoccupied.
- **Bypass button.** The bypass button forces the controller to comfort mode for a configurable period of time.

See STR100-107 data sheet and installation sheet for details.

2.2.4 Wall Module Configuration

Wall Module Choice

STR150 is enabled by *nciAppOptions* bit 14:

- 0 = ZS, STR100-104 or STR350/351 (default)
- 1 = STR150

This can be set using the LonMaker Xenta100 plug-ins in Toolpack version 2.01 or higher, or by means of TAC Xenta OP.

Initial Start Up Status

- SpaceTemp in the application is set to +20.00 Celsius (This can be read in *nvoSpaceTemp* but not in the *nviSpaceTemp*)
- Fan is set to Fan Auto

TAC Xenta can now accept data from the STR module.

If no room temperature readings are received within 10 minutes, the SpaceTemp in the application is set to “invalid”. This is shown as “invalid” in *nvoSpaceTemp*.

When the first update is received, then the 10-minute limit is changed to 5 minutes.

Unless there is a restart, the Offset + Fan values are not cleared and the last value is valid..



For more information on how to configure and engineer the STR series of wall modules see respective product documents.

2.3 Applications

2.3.1 General

The zone controller TAC Xenta 103-A is mainly designed for chilled ceilings in offices and other larger buildings. For chilled ceiling applications, the zone temperature is controlled by modulation of the chilled water flow to ceiling elements, so called cooling baffles, and the hot water flow to radiators.

Air quality control, window contact sensor and the occupancy sensor, are described in detail in:

- Chapter 5.3.4, “Air Quality Control”, on page 40,
- Chapter 5.3.5, “Window Contact”, on page 41,
- Chapter 5.3.6, “Occupancy Sensor”, on page 41.

2.3.2 The Zone Controller TAC Xenta 103-A

TAC Xenta 103-A can control a damper, used to cool the zone and to maintain the air quality. If the air quality is to be controlled, you need a carbon dioxide sensor, which is connected to, or send an SNVT, to the controller.

The temperature in the zone is kept constant by sequence control by the heating valve SV22, the air damper ST21 and the cooling valve SV21. When the cooling demand increases, the following occur:

- 1 The heating valve closes.
- 2 The the air damper, which is limited to its minimum and maximum positions, opens.
- 3 The cooling valve opens.
- 4 When the cooling demand decreases, the sequence is run in the opposite order.

There is a possibility to connect a carbon dioxide sensor to the controller and thus control the carbon dioxide level in the zone by modulating the air volume to the zone. When the carbon dioxide level passes a certain limit, the controller starts increasing the air flow to the zone. The position of the damper thus depends on the temperature control, the air quality control, and the minimum and maximum air flow limits.

When someone opens a window, the controller is stopped by the window contact sensor GW1. To avoid too low a temperature in the zone, the controller turns to heating if the zone temperature falls below 10 °C.

The occupancy sensor GX1 checks if someone is present in the zone and also gives the possibility to switch between operation modes.

See Chapter 5, "Functional Description", on page 31 for a more detailed description of the operation modes.

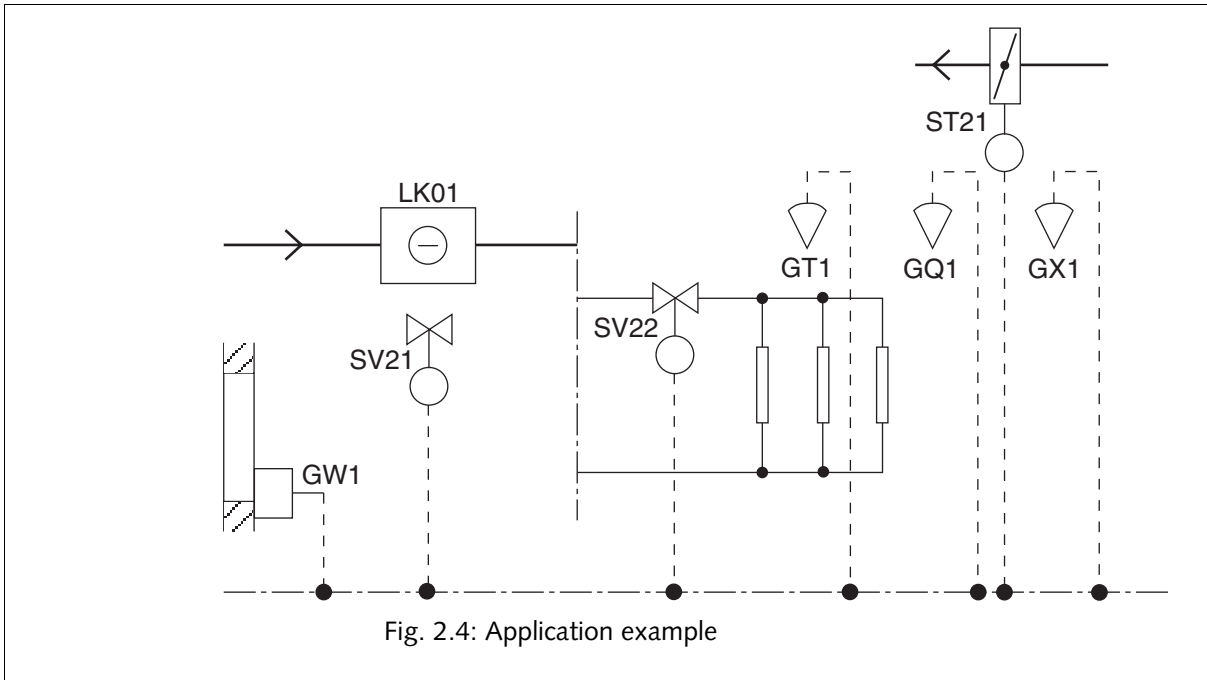

Fig. 2.4: Application example

3 Installation

3.1 Mechanical Installation

3.1.1 Fitting

TAC Xenta 103-A can either be snapped onto a DIN rail (Fig. 3.1) or fixed to a level surface with two screws (Fig. 3.2).

To fasten the controller onto a DIN rail:

- 1 Place the controller on the top of the rail as shown by arrow 1.
- 2 Twist the controller downwards until it snaps onto the rail as shown by arrow 2.
- 3 To remove, use a screwdriver to locate the bottom of the controller and pull down. Lift the controller diagonally upwards and off the rail.

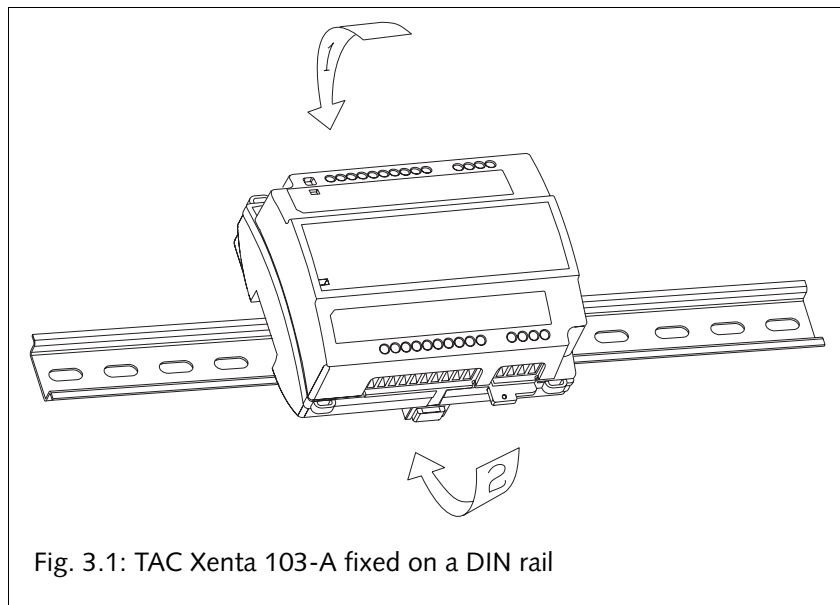
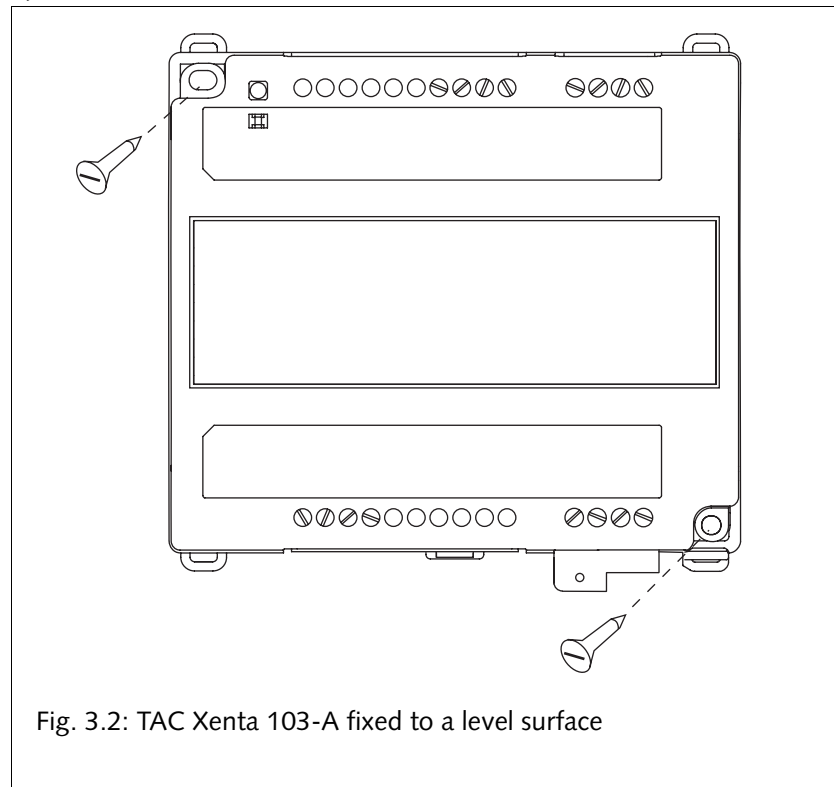

Fig. 3.1: TAC Xenta 103-A fixed on a DIN rail

Fixing the Controller to a Level Surface:

Use the two sockets provided for fixing the controller; the maximum screw size is M4 or ST 3,5. The head of the screw should not exceed 7,5 mm in diameter.



3.2 Electrical Installation

3.2.1 General



Warning!

All 230 V supply cables must be installed by authorized electricians.

- 1 Each controller or group of controllers must be fitted with max. 6 A fuses.
- 2 Avoid hanging or loose cables by using clamps to secure them to the controller.
- 3 A switch to cut off the power supply to the controller or complete unit must be easily accessible.
- 4 When several Xenta controllers receive power from a common transformer, it is important that all Gs are connected with each other and that all G0s are connected to each other. They must not be interchanged. Important exception: the G0 on the wall module

should be connected to the terminal OP on the controller and not to the other G0s. Instead it should be connected to the terminal OP on the controller. The G0 should be grounded at the transformer to prevent interference.

- 5 To ensure that the specified measuring accuracy is achieved, the two M terminals must be connected to the wall module.

NOTE: This equipment has been tested and found to comply with the limits for a Class B digital device, pursuant to part 15 of the FCC Rules. These limits are designed to provide reasonable protection against harmful interference in a residential installation. This equipment generates, uses and can radiate radio frequency energy and, if not installed and used in accordance with the instructions, may cause harmful interference to radio communications. However, there is no guarantee that interference will not occur in a particular installation. If this equipment does cause harmful interference to radio or television reception, which can be determined by turning the equipment off and on, the user is encouraged to try to correct the interference by one or more of the following measures:

- Reorient or relocate the receiving antenna.
- Increase the separation between the equipment and receiver.
- Connect the equipment into an outlet on a circuit different from that to which the receiver is connected.
- Consult the dealer or an experienced radio/TV technician for help.

Safety Standard

Transformers supplying the controller must comply to the safety standard EN 60 742 or any other relevant safety standard for ELV, 24 V AC, ETL listing: UL 3111-1, first version and CAN/CSA C22.2 No. 1010.1-92. When connecting equipment that has an independent power supply, for example an occupancy sensor, this power supply must also comply with this norm.

Cable Lengths

For information on communication cable lengths, see TAC Xenta Network Guide, part number 0-004-7461. For all other cables, maximum length is 30 m and min. area is 0,7 mm².

Wall Modules

The STR100-104 is primarily intended for use with the Xenta 103-A. The wall module STR150 can also be used, but in this case the fan speed button is not used. For more information about how to connect and configure the wall modules, please refer to the documentation for each respective product.

Connection Terminals

The designation of the connection terminals can be seen in two places on the controller: on the edge of the printed circuit board, and on the label on the front of the controller.

Table 3.1: Connection Terminals

Termin no.	Design.	Function	Type
1	C1	TP/FT-10 communication channel	-
2	C2	TP/FT-10 communication channel	-
3 ^a	X3	Window contact (Closed contact=closed window)	Digital input
4	M	Measurement neutral	-
5 ^a	X2	Occupancy sensor	Digital input
6	-	Not in use	
7	M	Measurement neutral	
8	Z1	Carbon dioxide sensor	Analogue input
9	D1	LED on wall module	Digital output
10	M	Measurement neutral	-
11	X1	Bypass key on wall module	Digital input
12	R1	Setpoint adjustment on wall module	10 k Ω linear potentiometer
13	M	Measurement neutral	-
14	B1	Room temperature sensor	Thermistor input
15	G	24 V AC (G)	Input
16	G0	24 V AC (G0)	Input
17 ^b	OP	24 V AC supply for TAC Xenta OP	-
18	G	24 V AC supply for TAC Xenta OP	-
19	V1	Heating valve: Actuator: increase Thermo actuator: on/off	Triac
20	G	24 V AC (G) supply for V1 and V2	-
21	V2	Heating valve: Actuator: decrease Thermo actuator: on/off	Triac
22	-	Not in use	
23	G	24 V AC (G) supply for actuator	-
24	G	24 V AC (G) supply for actuator	-
25	G0	24 V AC (G0) supply for actuator	-
26	Y2	Control signal actuator cooling valve	Analogue output
27	M	Measurement neutral	-
28	Y1	Control signal actuator cooling damper	Analogue output

a. See chap 4 Configuration parameters

b. Connected alone to G0 on the wall module. Must not be connected to G0 on the controller.

3.2.2 Wiring of TAC Xenta 103-A

Read Chapter 3.2.1, "General", on page 18 before you connect the cables as shown in the wiring diagram in Fig. 3.3.

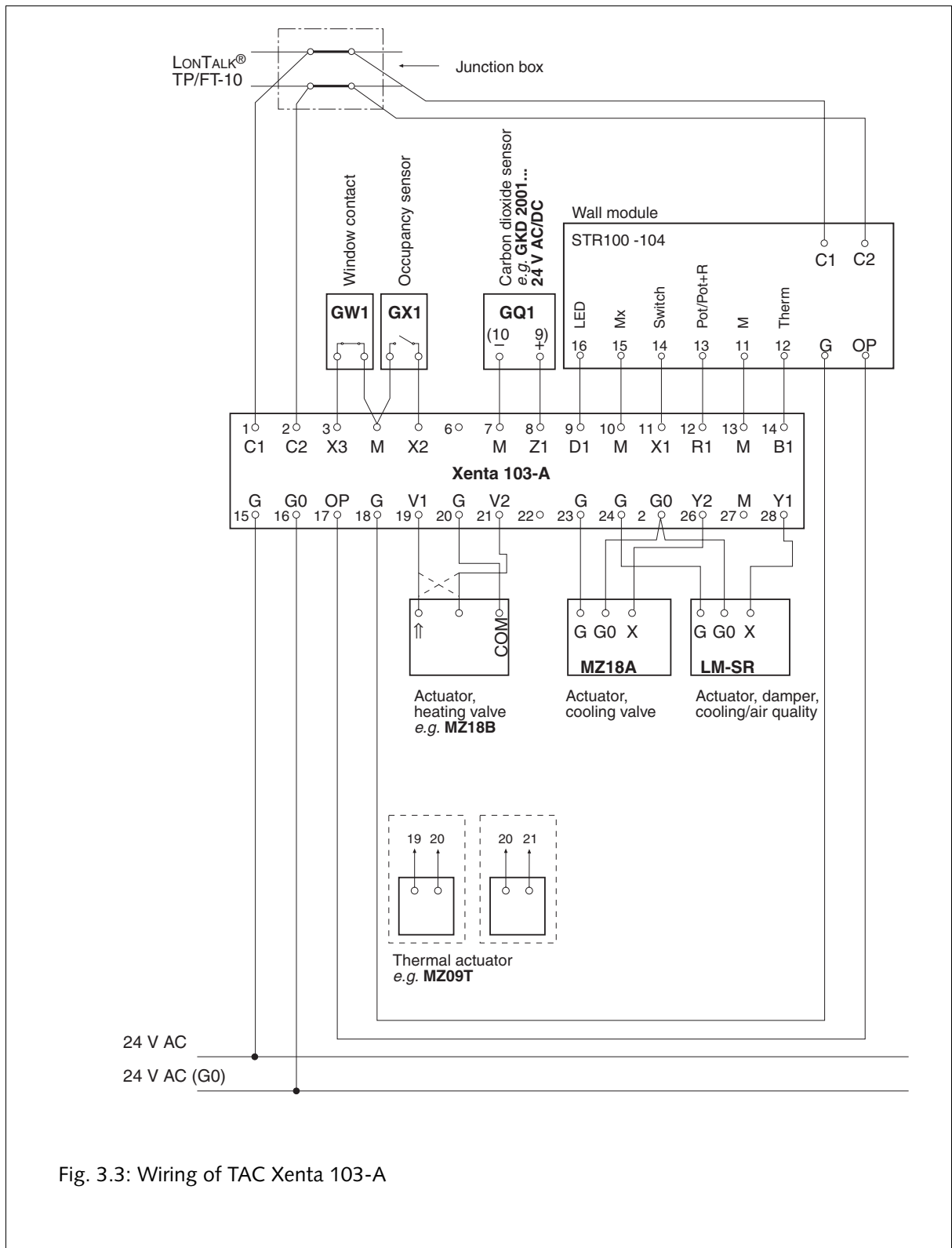

Fig. 3.3: Wiring of TAC Xenta 103-A

3.3 Commissioning

3.3.1 General

Once the mechanical and electrical installations have been completed the controller can be commissioned. This means:

- Installing the controller on the network, setting node status and giving it an address.
- Set the controller's configuration parameters.
- Bind network variables.
- Test the functions.

Before commissioning a complete zone system, read the manual “TAC Xenta - Zone Systems Guideline”. You could use TAC Xenta OP for setting the basic parameters. Use a network management tool or TAC Vista for commissioning the controller on the network and then do the rest of the commissioning.

How to use the TAC Xenta 100 as a stand-alone unit:

- 1 Use TAC Xenta OP to set the node status to "Configured".
- 2 Use TAC Xenta OP to set the basic parameters.
- 3 Use TAC Xenta OP to set all other parameters and variables.

Commissioning can also be achieved using a network management tool.

3.3.2 Node Status

The node status indicates which network configuration or program mode the controller is in. The node status can be changed using TAC Vista (version 3.1 or later), a network management tool. TAC Xenta OP can also be used on some occasions. The controller can be in these states:

Unconfigured

The controller is not configured when it leaves the factory. Neither the program nor the network communication are running. The service light emitting diode is flashing.

The controller must be configured before it can operate in a network (on line), see below.

You cannot set configuration parameters or network variables in this state.

Configured, Online

Use TAC Xenta OP, TAC Vista or a network management tool to change the status to configured. When this has been done, the program

and the network communication will be fully operational. The service LED is off. This is the normal state for a controller when it is operating.

The controller will use the address given by the tool during configuration. As TAC Xenta OP cannot be used to set an address, all controllers are given a default address. This means that TAC Xenta 100 can only be used as a stand-alone controller and cannot be used in a network..

The parameters and variables can now be set.

Configured, Soft Online

A network management tool is needed for this operation. The controller is programmed and configured for a network, but the program and communications are idle. The light emitting diode is off. If the controller is reset, it will go into configured, online.

Configured, Hard Online

A network management tool is needed for this operation. The controller is programmed and configured for a network, but the program and communications are idle. The light emitting diode is off. If the controller is reset, it will go remain in this state.

Without a Program and not Configured

This states indicates that there is something wrong with the controller. No program can be detected. The light emitting diode is lit.

3.3.3 Configuration Parameters (nci's)

TAC Xenta 100 has a number of configuration parameters that can be used to set the parameters of the controller. (See Chapter 4, “Configuration Parameters”, on page 25.) There are also network variables to control the controller during when it is operating.

Use the commissioning protocol in Appendix B to write down your settings when commissioning. See Chapter 8, “Communication”, on page 53, for more information about all parameters and variables, such as their index, accepted values, normal values.

3.3.4 Network Installation

For network installation, you need either a network management tool (LNS based or not) or TAC Vista. Examples of network management tools are MetraVision and ICELAN-G. (For more information see “TAC Xenta, Guidelines for zone applications”.)

The installation requires two steps:

- 1** Feed information about the controllers’ unique neuron-ID into the network management tool’s data base.
- 2** Allow the network management tool to install the controller on the network. The controller will automatically be given an address.

There are two ways to feed the neuron-ID into the data base:

- 1 Manually feed the neuron-ID into the network management tool. To make this easier you can use a bar code reader to read the detachable ID-neuron label, that is attached to every controller. It can be a good idea to collect these labels when you make the basic configuration, and stick them to a form, drawing or similar. There is a form for this purpose in the "TAC Xenta, Guidelines for zone applications" manual.
- 2 Use the service pin function. You can only do this when the controller is connected to the network. There is a service pin key in a hole in the upper left hand corner of the controller by terminal C1. Push the key to instruct the controller to send out its neuron-ID. The network management tool can then read the neuron-ID from the network and to save it in its data base.

3.3.5 Network Variable Binding

The binding method is determined by the type of network management tool to be used. Detailed information can be found in the tool's documentation. A description of how to bind network variables with Metra Vision can be found in the "TAC Xenta Network manual".

Binding network variables is not an issue when the controller is used in a stand-alone operation.

3.3.6 Function Test

Check that the controller controller works as intended.

All the controller's functions are described in Chapter 5, "Functional Description", on page 31.

4 Configuration Parameters

All communication with the controller is made using network variables.

- *nci's* are used to configure the controller. *nci's* are normally set during commissioning, and are not altered during normal operation (the parameters are stored in a special memory, and can be changed a maximum of 10 000 times).
- *nvi's* are used during operation.
- *nvo's* are output variables, which the controller sends out on the network.

Please see Chapter 8, “Communication”, on page 53 for a detailed information about accepted values and normal values for all parameters. All configuration parameters have default values on delivery.

4.1 Basic Parameters

nciAppOptions

These parameters are used to set selectable functions in the controller. The parameter consists of 16 bits, where each bit represents one function choice. The bits 12 through 14 are not used. When you look at *nciAppOptions* with TAC Xenta OP, bit 0 is shown to the left. There is an overview of all the bits' functions in table 4.1.

Table 4.1: The function of different bits in *nciAppOptions*.

Bit no.	Function
Bit 0	0 Occupancy sensor not connected, terminal X2
	1 Occupancy sensor connected, terminal X2
Bit 1	0 Energy hold off device (window contact) not connected, terminal X3
	1 Energy hold off device (window contact) connected, terminal X3
Bit 2	0 Heating valve enabled
	1 Heating valve disabled
Bit 3	0 Cooling valve enabled
	1 Cooling valve disabled
Bit 4	0 Damper cooling enabled
	1 Damper cooling disabled
Bit 5	0 Air quality control disabled
	1 Air quality control enabled
Bit 6	0 Actuators are increase/decrease models
	1 Actuators are thermo-actuators NC/NO
Bit 7	0 Slave mode disabled
	1 Slave mode enabled
Bit 8	0 Occupancy sensor: closed contact indicates occupancy
	1 Occupancy sensor: open contact indicates occupancy
Bit 9	0 If <i>nviSetpoint</i> has a valid value, the heating/cooling setpoints for the comfort and economy modes are calculated using method B.
	1 If <i>nviSetpoint</i> has a valid value, the heating/cooling setpoints for the comfort and economy modes are calculated using method A (Section 5.2.4, "Setpoint Calculation", on page 34).
Bit 10	0 Output Y2 gives 0-10 V
	1 Output Y2 gives 2-10 V
Bit 11	0 Thermo-actuators normally closed (NC)
	1 Thermo-actuators normally open (NO)
Bit 14	0 ZS, STR101-104 or STR350/351 wall modules
	1 STR150 wall module with display
Bit 15	Reserved for production test. Should not be altered!

Bit 12 through bit 13 are not used.

4.2 Other Configuration Parameters

The controller's other configuration parameters are listed below together with a short description. See also Chapter 8, "Communication", on page 53.

Table 4.2: Other configuration parameters.

Index	Name	Description
0	<i>nciLocation</i>	Location label
23	<i>nciSetpoints</i>	Occupancy temperature setpoints
24	<i>nciSpaceTempDev</i>	Max. deviation of zone temp.
25	<i>nciSpaceTempLow</i>	Low limit of zone temp.
26	<i>nciGainHeat</i>	Gain for heating controller
27	<i>nciItimeHeat</i>	Integral time for heating controller
28	<i>nciHeatActStTime</i>	Stroke time for heating actuator
29	<i>nciGainCool</i>	Gain for cooling controller
30	<i>nciItimeCool</i>	Integral time for cooling controller
31	<i>nciGainDamper</i>	Gain for damper controller
32	<i>nciItimeDamper</i>	Integral time for damper controller
33	<i>nciSpaceTempOfst</i>	Zone temp. sensor adjustment
34	<i>nciCO2PerVolt</i>	Conv. factor ppm CO ₂ per volt
35	<i>nciSpaceCO2Low</i>	Zone CO ₂ level for closed damper
36	<i>nciSpaceCO2High</i>	Zone CO ₂ level for open damper
37	<i>nciDamperMinPosn</i>	Air damper min. position
38	<i>nciDamperMaxPosn</i>	Air damper max. position
41	<i>nciHeatPrimMin</i>	Minimum output heating controller
42	<i>nciInstallType</i>	Network configuration source
43	<i>nciSndHrtBt</i>	Send heartbeat
44	<i>nciRcvHrtBt</i>	Receive heartbeat

nciLocation

nciLocation is used to name the place where the controller is installed. In the operating panel, this parameter is shown as the first variable (see also Chapter 8.2, "Default Settings and Power on", on page 53).

nciSetpoints

nciSetpoints is used to set the setpoint temperatures for heating and cooling in comfort, economy and off mode (see also Chapter 5.2.1, "Operation Modes", on page 31 and Chapter 5.2.4, "Setpoint Calculation", on page 34).

nciSpaceTempDev

nciSpaceTempDev is used to set the maximum allowed deviation of the zone temperature (Chapter 5.2.4, "Setpoint Calculation", on page 34). Default value 2 °C.

nciSpaceTempLow

nciSpaceTempLow is used to set the lowest allowed zone temperature (Chapter 5.3.8, “Alarm”, on page 43). Default value 10 °C.

nciGainHeat, nciGainCool

nciGainHeat and *nciGainCool* are used to set the gain for the heating/cooling controllers. Default value 25.

nciItimeHeat, nciItimeCool

nciItimeHeat and *nciItimeCool* are used to set the I-time for the heating/cooling controllers. Default values 1500 s (25 min) / 900 s (15 min).

nciHeatActStTime

nciHeatActStTime is set according to the runtime of the actuator. Default value 165 s.

nciGainDamper

nciGainDamper gives the gain for cooling for the damper. Default value 25.

nciItimeDamper

nciItimeDamper is used to set the I-time for cooling for the damper. Default value 900 s (15 min).

nciSpaceTempOfst

nciSpaceTempOfst is used to adjust the temperature setpoints at the wall module. Default value 0.0 °C.

nciCO2PerVolt

nciCO2PerVolt holds the conversion factor to get the carbon dioxide level in the zone by means of the output from the carbon dioxide sensor. Default value 220 ppm/V.

nciSpaceCO2Low

nciSpaceCO2Low is used to set the carbon dioxide level at closed damper. Default value 400 ppm.

nciSpaceCO2High

nciSpaceCO2High is used to set the carbon dioxide level at open damper. Default value 1000 ppm.

nciDamperMinPosn

nciDamperMinPosn is used to set the smallest damper opening allowed. Default value 30%.

nciDamperMaxPosn

nciDamperMaxPosn is used to set the largest damper opening allowed. Default value 100%.

nciHeatPrimMin

nciHeatPrimMin is used to set the smallest heating valve opening allowed (see also Chapter 5.3.7, “Minimum Value for Heating Valve”, on page 42). Default value 0%.

nciSndHrtBt

nciSndHrtBt is used to determine how often the nvo’s, which are transmitted continuously on the net, should be sent (see also Chapter 8.3, “Monitoring Network Variables, Heartbeat”, on page 54).

nciRcvHrtBt

nciRcvHrtBt is used to determine how long time max. there may be between updating the nvi’s, for which the controller expects continuous updating (see also Chapter 8.3, “Monitoring Network Variables, Heartbeat”, on page 54).

5 Functional Description

5.1 General

The controller's function is determined by its node status, operation modes and the methods used to force the controller for well-adapted zone temperature control. The controller, which has a built-in damper function, measures the zone temperature, and uses various methods to calculate setpoints. Apart from the basic functions, the controller can also be used to control the climate in the zone.

Each section in this chapter ends with information about how network variables are used in the current control situation. If you need details about the network variables' characteristics, such as default values and accepted values, see Chapter 8, "Communication", on page 53.

5.2 The Controller's Basic Functions

5.2.1 Operation Modes

The controller has four selectable operation modes:

- Comfort
- Economy
- Bypass
- Off

The operation mode is controlled by *nviManOccCmd*, but is also influenced by occupancy sensors and the bypass key on the wall module. The relationship between operation modes is shown in Table 5.1, "The relationship between operation mode, bypass timer, occupancy sensor, current operation mode and nvoEffectOccup."

Table 5.1: The relationship between operation mode, bypass timer, occupancy sensor, current operation mode and *nvoEffectOccup*.

Operation mode <i>nviManOccCmd</i>	Bypass timer ^a	Occupancy sens. ^b	Current op. mode	<i>nvoEffectOccup</i>
Comfort OC_OCCUPIED	Enabled	No Effect.	Comfort	OC_OCCUPIED
	At a stand-still	Occupancy detect. ^c No occupancy	Comfort Economy	OC_OCCUPIED OC_STANDBY
Economy OC_STANDBY	Enabled	No Effect.	Bypass	OC_BYPASS
	At a stand-still	No Effect.	Economy	OC_STANDBY
Off OC_UNOCCUPIED	Enabled	No Effect.	Bypass	OC_BYPASS
	At a stand-still	No Effect.	Off	OC_UNOCCUPIED
Stand-alone OC_NUL	Enabled	Occupancy detect. ^c No occupancy	Comfort Bypass	OC_OCCUPIED OC_BYPASS
	At a stand-still	Occupancy detect. ^c No occupancy	Comfort Off	OC_OCCUPIED OC_STANDBY
OC_BYPASS	Without significance	No Effect	Bypass	OC_BYPASS

a. Activated by the bypass key on the wall module

b. See Chapter 5.3.6, “Occupancy Sensor”, on page 41

c. No sensor connected will result in OC_OCCUPIED

Comfort Mode

This is the default mode, that is to say when someone is in the zone the controller should ensure that the climate in the room is comfortable. The controller is in this mode when *nviManOccCmd*=OC_OCCUPIED (or OC_NUL after a power down).

The LED on the wall module is lit with a steady green light and you can use the setpoint knob on the wall module and the air quality control is enabled. The setpoints used are found in *nciSetpoints* (can be modified). The controller gets the heating setpoint if the current setpoint is within the comfort mode neutral zone.

The alarms for the zone temperature deviation and high carbon dioxide levels will cut out if the deviation or the level pass their alarm limits. The alarm for window contact and low zone temperature are blocked.

Economy Mode

In economy mode, the controller lowers the energy consumption in the zone by using the heating and cooling setpoints for economy in *nciSetpoints* (can be modified). The controller is in this mode when *nviManOccCmd* = OC_STANDBY and the bypass button has not been pressed.

The LED of the wall module flashes slowly. The bypass button and the setpoint knob can be used to make a manual setting. The air quality control is enabled.

The alarms for low zone temperature and window contact may cut out. The alarms for high carbon dioxide level and for zone temperature deviation are blocked.

Bypass Mode

The bypass key on the wall module is used if you occasionally want to change to comfort mode from economy or off mode.

When someone presses the bypass key on the wall module, the bypass timer starts and the controller turns to bypass mode. The bypass timer runs for two hours, and after , after which the controller changes operation mode, see Table 5.1, “The relationship between operation mode, bypass timer, occupancy sensor, current operation mode and nvoEffectOccup.”. The controller’s bypass mode acts as the comfort mode during those two hours and the setpoints and alarms operate as in comfort mode.

Off Mode

When the zone is not used for a longer period of time, the controller can be set to off mode. The controller is in this mode when *nviManOccCmd*=OC_UNOCCUPIED.

The light emitting diode on the wall module is out, and controls by heating and cooling demand according to the setpoint in *nciSetpoints*.

The bypass key, the low zone temperature alarm and window contact alarm are not blocked. The air quality control is blocked, as well as the setpoint setting, the alarms for deviation in zone temperature and for high carbon dioxide level.

Index	Variable name	Description
1	<i>nvoEffectOccup</i>	Effective occupancy output
12	<i>nviManOccCmd</i>	Occupancy scheduler input
23	<i>nciSetpoints</i>	Occupancy temperature setpoints

5.2.2 Forcing the Controller

TAC Xenta 103-A changes between heating and cooling according to Fig. 5.1.

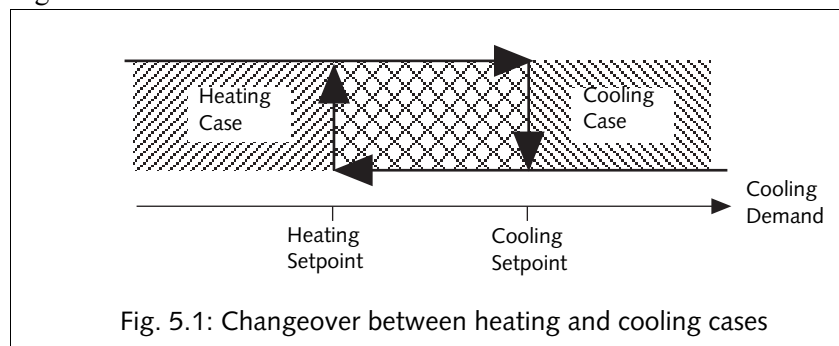

You can force the controller to heat only or cool only, just as you can force it to neither heat nor cool, and to run the fan only. This is achieved using *nviApplicMode*, see Table 5.2, “*nviApplicMode*”.

Table 5.2: *nviApplicMode*

<i>nviApplicMode</i>	Forcing	Description
HVAC_AUTO	Automatic	The controller automatically changes over between heating and cooling.
HVAC_HEAT	Heating only	The controller can only heat. The cooling setpoint is neglected. The air quality control is enabled and the damper is limited to its open and closed positions.
HVAC_COOL	Cooling only	The controller can only cool. The heating setpoint is neglected. The air quality control is enabled and the damper is limited to its open and closed positions.
HVAC_NIGHT_PURGE	Night cooling	The controller can only cool with the air flow from the damper. The heating and cooling valves are closed. The air quality control is disabled.
HVAC_OFF	Off	Valves, dampers and air quality control are disabled. Only the low zone temperature protection is enabled.

Table 5.3:

Index	Variable name	Description
13	<i>nviApplicMode</i>	Application mode input

5.2.3 Measuring Zone Temperature

Measure the zone temperature either with a permanent thermistor sensor (the wall module) or with a LonTalk temperature sensor node connected to *nviSpaceTemp*. If *nviSpaceTemp* has a valid value the controller will use it, if it doesn't the thermistor value will be used. The thermistor value can be adjusted by *nciSpaceTempOfst* having received a value; this is added to the thermistor value. The value the controller uses is also put out on *nvoSpaceTemp*. If neither value is valid, *nvoSpaceTemp* will receive the off value.

nvoSpaceTemp is sent when it has changed by at least 0.1°C..

Index	Variable name	Description
5	<i>nvoSpaceTemp</i>	Zone temperature output
14	<i>nviSpaceTemp</i>	Zone temperature input
33	<i>nciSpaceTempOfst</i>	Zone temperature sensor adjustment

5.2.4 Setpoint Calculation

Zone Temperature Setpoints

nciSetpoints define six temperature setpoints. The smallest accepted deviation between the heating and cooling setpoints is 0,5 °C, and the heating setpoints must be lower than the cooling setpoints. If the heating setpoints are higher or equal to the cooling setpoints, the controller resets the heating setpoint to 0.5 °C lower than the cooling setpoint.

Table 5.4, “The setpoints in *nciSetpoints*.” shows accepted values and default values for the six temperature setpoints in *nciSetpoints*.

Table 5.4: The setpoints in *nciSetpoints*.

Setpoint	Min.	Max.	Normal
Cooling setpoint comfort	10 °C	35 °C	23 °C
Heating setpoint comfort	10 °C ^a	35 °C	21 °C
Cooling setpoint economy	10 °C	35 °C	25 °C
Heating setpoint economy	10 °C ^a	35 °C	19 °C
Cooling setpoint off	10 °C	35 °C	28 °C
Heating setpoint off	10 °C ^a	35 °C	16 °C

a. If the cooling setpoint is 10 °C, the heating setpoint is set to 9,5 °C.

The setpoints for comfort and economy mode are basic setpoints, which can be changed with *nviSetpoint*, *nviSetPntOffset* and the setpoint knob. The off mode setpoints are always valid.

Calculation

The current setpoint, *nvoEffectSetpt*, depends on the current operation mode (*nvoEffectOccup*), current operation mode, (*nvoUnitStatus*; mode), and *nviSetpoint*, *nviSetpntOffset*, *nciAppOptions*, *nciSetpoints* and a possible local setpoint adjustment via the wall module. Fig. 5.2

shows the relationship between the variables used for setpoint calculation.

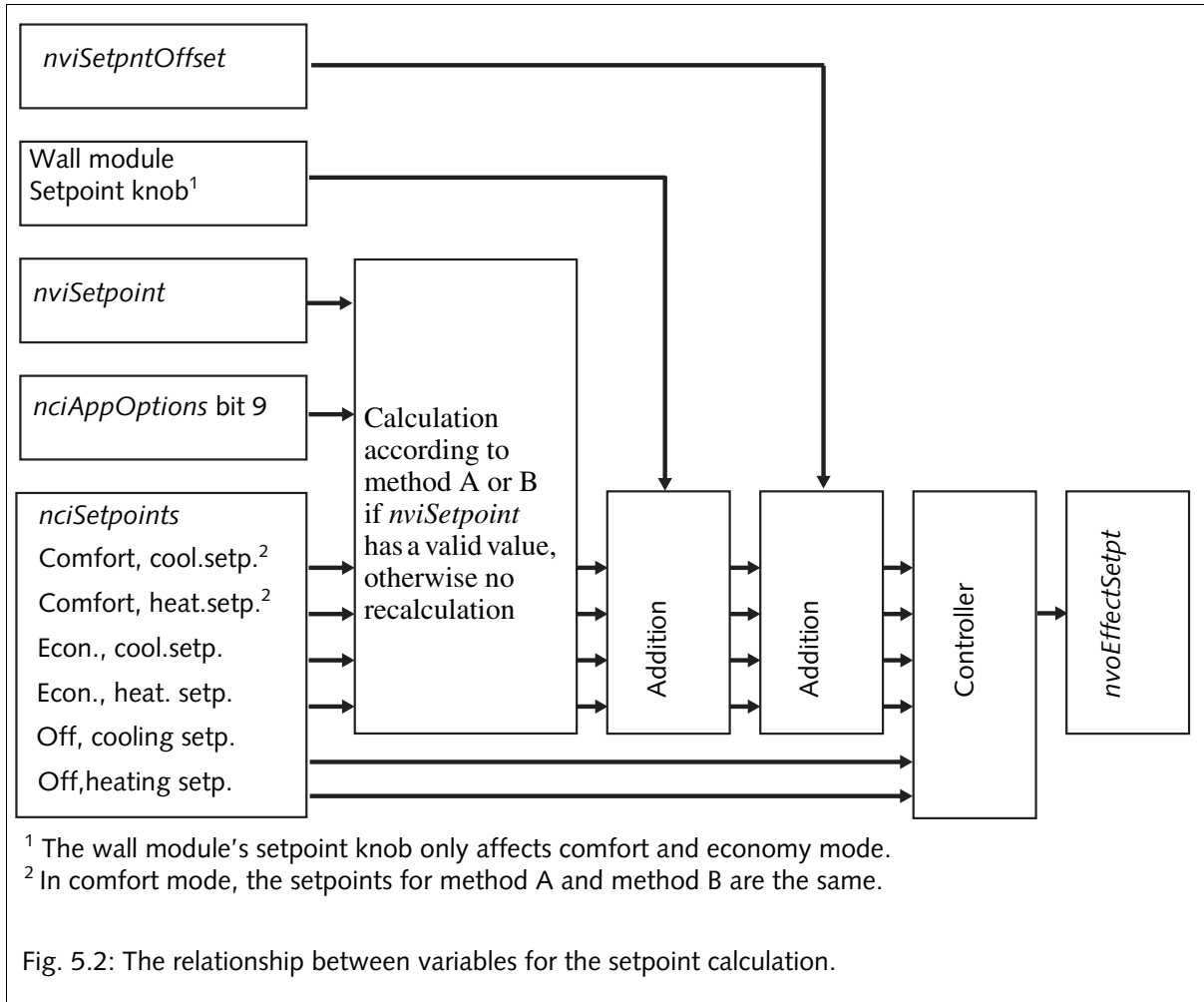

nviSetpoint is used to allow the temperature setpoints in comfort and economy mode to be changed via the network. If there is a valid value on *nviSetpoint*, the controller calculates the setpoints for comfort and economy mode with method A or method B (the methods are described in Appendix A).

The choice of method is made via *nciAppOptions*, bit 9. If bit 9=0 method B is used, and if 9=1 method A is used. If there is no valid value on *nviSetPoint*, no recalculation of the temperature setpoints in *nciSetpoints* is made.

nviSetPntOffset can be seen as a setpoint adjustment from a wall module connected to the network. Its value is added to setpoints for comfort and economy mode.

In Appendix A there are detailed calculation examples of setpoint calculations.

Index	Variable name	Description
2	<i>nvoUnitStatus</i>	Unit status output
4	<i>nvoEffectSetpt</i>	Effective setpoint output
13	<i>nviApplicMode</i>	Application mode input
15	<i>nviSetPoint</i>	Temperature setpoint input
16	<i>nviSetpntOffset</i>	Setpoint offset input
22	<i>nciAppOptions</i>	Application options
23	<i>nciSetpoints</i>	Occupancy temperature setpoints

5.2.5 Control Sequence

The zone temperature is kept constant by sequence control of a heating valve, a cooling damper, and a cooling valve. Depending on which type of heating actuator is used, the control sequence differs somewhat, which is shown in the figure below.

The sequence for zone temperature control at increasing cooling demand is:

- 1 close heating
- 2 valve open cooling damper
- 3 open cooling valve.

At decreasing cooling demand the sequence is reversed.

The control sequence is controlled by three separate PI controllers as it is possible to disable each function.

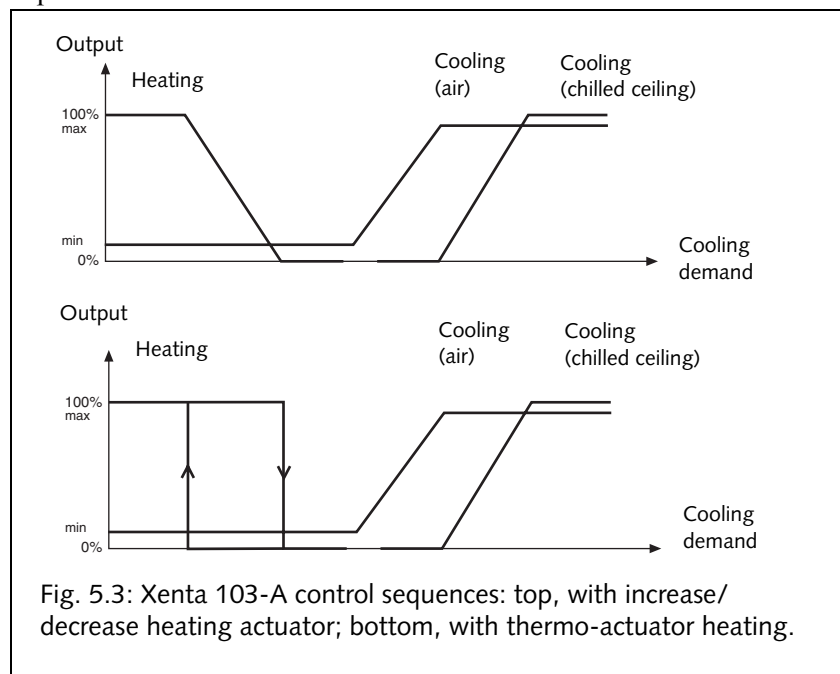

5.3 More About Functions

5.3.1 Heating Control

The heating control is done with an increase/decrease actuator or an on/off signal for thermo-actuators. Actuator is selected with bit 6 in *nciAppOptions*.

When the on/off signal (thermo-actuator) is selected, the outputs V1 and V2 are connected in parallel. The actuator type should be “normally closed”, i.e. a set output is the same as opening the valve.

A thermo-actuator is started when the zone temperature falls below the current setpoint and is turned off when the zone temperature passes the current setpoint. The change is performed with a 0.1°C hysteresis.

nvoHeatPrimary and the heating setpoint in *nvoUnitStatus* show the current heating output level. *nvoHeatPrimary* can be used to remote control a heating source.

Accepted values for these variables are from 0% to 100% of the heating capacity. The value 163.83% is sent as a not valid value to show that the heating step is blocked.

Heating control	
Type:	PI
Gain:	0–32.75; normal 25
I-time:	0–60 minutes, normal 25 minutes
Dead band:	0.2 °C
Run time:	5–600 s; normal 165 s
Control interval:	60 s

Index	Variable name	Description
2	<i>nvoUnitStatus</i>	Unit status output
6	<i>nvoHeatPrimary</i>	Heating control output
22	<i>nciAppOptions</i>	Application options
26	<i>nciGainHeat</i>	Gain for heating controller
27	<i>ncitimeHeat</i>	Integral time for heating controller

5.3.2 Cooling Control (Chilled Ceiling)

The cooling valve is controlled by an analogue output (0-10 V or 2-10 V), where 10 V corresponds to a completely open valve.

nvoCoolSecondary and the cooling setpoint in *nvoUnitStatus* show current output level for the chilled ceiling elements.

Accepted values for these variables are from 0% to 100% of the cooling capacity. The value 163.83% is sent as a not valid value to show that cooling via the chilled ceiling elements is blocked..

Cooling control	(chilled ceiling)
Type:	PI
Gain:	0–32.75; normal 25
I-time:	0–60 minutes, normal 15 minutes
Dead band:	0.2 °C
Control interval:	60 s

Index	Variable name	Description
2	<i>nvoUnitStatus</i>	Unit status output
9	<i>nvoCoolSecondary</i>	Cooling control output
22	<i>nciAppOptions</i>	Application options
29	<i>nciGainCool</i>	Gain for cooling controller
30	<i>ncitimeCool</i>	Integral time for cooling controller

5.3.3 Cooling Controller (air)

The cooling damper is controlled by an analogue output (0 to 10 V), where 10 V corresponds to a completely open damper. The damper position is limited by minimum and maximum values which are controlled by the variables *nciDamperMinPosn* and *nciDamperMaxPosn*. The minimum and maximum values for the damper positions must be given in an interval from minimum to maximum, i.e. *nciDamperMinPosn* must always have a smaller value than *nciDamperMaxPosn*.

nvoCoolPrimary and the cooling setpoint in *nvoUnitStatus* show the current cooling damper output level. The variable *nvoCoolPrimary* can be used to remote control a damper actuator.

Accepted values for these variables are from 0% to 100% of the heating capacity. The value 163.83% is sent as a not valid value to show that cooling by air is blocked.

Cooling control	(air volume)
Type:	PI
Gain:	0–32.75; normal 25
I-time:	0–60 minutes, normal 15 minutes
Dead band:	0.2 °C
Control interval:	60 s

Index	Variable name	Description
2	<i>nvoUnitStatus</i>	Unit status output
8	<i>nvoCoolPrimary</i>	Damper position output
22	<i>nciAppOptions</i>	Application options
31	<i>nciGainDamper</i>	Gain for damper controller
32	<i>nciItimeDamper</i>	Integral time for damper controller
37	<i>nciDamperMinPosn</i>	Air damper min. position
38	<i>nciDamperMaxPosn</i>	Air damper max. position

5.3.4 Air Quality Control

To ensure the quality of air is good the TAC Xenta 103-A controls the air flow to the controlled zone. If the carbon dioxide sensor shows a high level of CO₂ the controller increases the air flow to the controlled zone.

The air flow is proportional to the carbon dioxide level and is calculated as a linear function between [*nciSpaceCO2Low*, *nciDamperMinPosn*] and [*nciSpaceCO2High*, *nciDamperMaxPosn*].

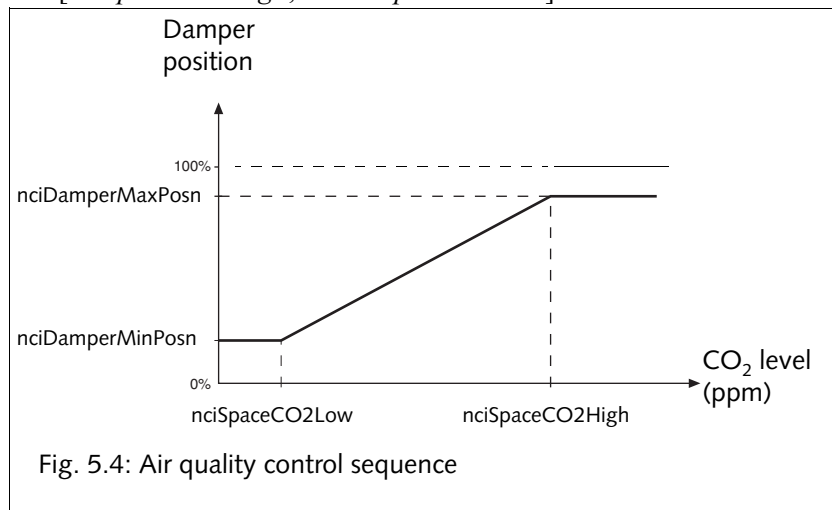

Fig. 5.4: Air quality control sequence

The air flow is set to the highest value of the value from the air quality control and the cooling controller according to figure.

The air quality control can be enabled independent of the cooling controller and is only enabled in comfort and bypass mode.

The carbon dioxide level can be measured with a permanent carbon dioxide sensor. The controller converts the analogue 0–10 V signal to a concentration in ppm by multiplying it with the variable *nciCO2PerVolt* (ppm/volt). As an alternative, you can use a LonTalk carbon dioxide measurement node in connection with the variable *nviSpaceCO2*. If *nviSpaceCO2* has a valid value, the variable has a higher priority than the electrically connected sensor.

For the damper not to be opened or closed unnecessary, the CO₂ level must deviate with more than ± 30 ppm from the last reading.

nvoSpaceCO2 shows the current carbon dioxide level in the zone. If *nviSpaceCO2* has a valid value, the current carbon dioxide level will be identical to the input.

The current CO₂ value is always sent, no matter which options are set in the variable *nciAppOptions*. The air quality control is enabled when bit 5=1 in *nciAppOptions*.

Index	Variable name	Description
10	<i>nvoSpaceCO2</i>	Zone CO ₂ sensor output
17	<i>nviSpaceCO2</i>	Zone CO ₂ input
22	<i>nciAppOptions</i>	Application options
34	<i>nciCO2PerVolt</i>	Conv. factor ppm CO ₂ per volt
35	<i>nciSpaceCO2Low</i>	Zone CO ₂ level for closed damper
36	<i>nciSpaceCO2High</i>	Zone CO ₂ level for open damper
37	<i>nciDamperMinPosn</i>	Air damper min. position
38	<i>nciDamperMaxPosn</i>	Air damper max. position

5.3.5 Window Contact

TAC Xenta 103-A is designed to be able to limit the energy consumption when a window in the room is open. You can connect a local sensor directly to the controller, digital input X3, or use *nviEnergyHoldOff*. The energy hold off is enabled when either of these signals indicate an open window. The energy hold off is made by the controller being set to off mode. Open X3 input means open window.

To be able to use a sensor (local or connected to the network), bit 1 in *nciAppOptions* must be set to 1.

nvoEnergyHoldOff has the value of the locally connected sensor. This is true even if bit 1 in *nciAppOptions* is set to 0.

If the energy hold off has been active for 60 seconds the window contact alarm cuts out, bit 2 in *nvoAlarmstatus* (this only applies to Economy and Off-modes).

Index	Variable name	Description
3	<i>nvoAlarmstatus</i>	Alarm status output
11	<i>nvoEnergyHoldOff</i>	Energy hold off output
18	<i>nviEnergyHoldOff</i>	Energy hold off input
22	<i>nciAppOptions</i>	Application options

5.3.6 Occupancy Sensor

A sensor can be connected to TAC Xenta 103-A to determine whether the room is occupied or not. If no occupancy sensor is connected, the

controller supposes that the room is always occupied. The controller uses the information to determine whether the operation mode should be comfort or economy. When the controller is used as a stand-alone unit, the sensor is used to choose between comfort mode or off mode. See Table 5.1, “The relationship between operation mode, bypass timer, occupancy sensor, current operation mode and nvoEffectOccup.”

The sensor can be connected either directly to the controller, input X2, or via the network, *nviOccSensor*. To be able to use a sensor that is directly connected, bit 0 in *nciAppOptions* must be set to 1. When *nviOccSensor* has received a valid value, this is used, whether the sensor is directly connected or not.

Bit 8 in *nciAppOptions* indicates whether input X2 should signify presence or absence. Bit 8=0 signifies that an closed input X2 means presence. Bit 8=1 signifies that an open input X2 means presence.

The directly connected sensor’s value is sent out on the network in *nvoOccSensor*. If there is no sensor connected (according to *nciAppOptions*), the value OC_NUL is sent out.

There is a 20 minute delay before the operation mode is changed from comfort to economy in *nvoEffectOccup*. The change in *nvoOccSensor* only takes 250 ms to make other uses of the occupancy sensor possible (lighting, alarm etc).

Index	Variable name	Description
22	<i>nciAppOptions</i>	Application options
39	<i>nvoOccSensor</i>	Occupancy sensor output
40	<i>nviOccSensor</i>	Occupancy sensor input

5.3.7 Minimum Value for Heating Valve

To avoid back draught at windows during cold periods, TAC Xenta 103-A offers a possibility to heat even if it is not really necessary to keep the temperature in the room.

Increase/decrease actuator

Increase/decrease actuator is done by setting a lowest value for the opening of the heating valve. TAC Xenta 103-A makes sure that the opening never falls below this value. The value is given as a percentage in *nciHeatPrimMin* (lowest output heating valve). To accomplish this function the controller needs to know the real actuator position. For this purpose a min.-position calibration is performed at certain occasions. This is done by forcing the decrease output during 5 min. allowing the actuator to reach its minimum position. This operation takes place once every day and also at operating mode changes and at a randomly chosen time after power up.

Thermo-actuator

The percentage in *nciHeatPrimMin* is recalculated to a degree number. This degree number is used to simulate a lower room temperature than the usual and thus get additional heating.

Index	Variable name	Description
41	<i>nciHeatPrimMin</i>	Minimum output heating controller

5.3.8 Alarm

When TAC Xenta 103-A reports alarms to a monitoring system it is achieved using the network variable *nvoAlarmStatus*. The variable has 16 bits, each of which correspond to different alarm situations.

Table 5.5: Alarm modes for *nvoAlarmStatus*.

Bit no	Alarm	Cuts out when...	Is reset when...
0	Deviating zone temperature	The deviation in zone temp. is larger than <i>nciSpaceTempDev</i> for more than 60 minutes (Comfort mode).	The deviation in zone temp. is smaller than the value in <i>nciSpaceTempDev</i> (hysteresis 0.5 °C).
1	Low zone temperature	The zone temp. is lower than the value in <i>nciSpaceTempLow</i> for more than 60 min (Economy and off mode).	The zone temp. is more than 2°C above the value in <i>nciSpaceTempLow</i> .
2	Window contact alarm	Energy hold off (window contact) is active for more than 60 s (Economy and off mode).	The controller no longer detects the state.
3	High carbon dioxide level	The carbon dioxide level is higher than <i>nciSpaceCO2High</i> (Comfort mode).	The carbon dioxide level is lower than the value in <i>nciSpaceCO2High</i> .
10	Not bound variables have been set to default values.	Power on. (Power cycle)	When the first not bound variables have been updated.
11	Adaptation of thermistor does not work	Internal writing error in the controller memory.	The controller must be replaced.
12	Bound network variables not received	Bound network variables have not been received within set time. <i>nciRcvHrtBt</i>	When network variables have been received.
13	Not valid value on input	An input network variable falls outside its accepted values.	The variable is given an accepted value.
14	No application program	No valid application program.	The application program is loaded. Contact the nearest TAC service point.
15	Cannot write to EEPROM	The controller is faulty.	The controller must be replaced.

Index	Variable name	Description
3	<i>nvoAlarmStatus</i>	Alarm status output
24	<i>nciSpaceTempDev</i>	Max. deviation of zone temperature
25	<i>nciSpaceTempLow</i>	Low limit of zone temperature
36	<i>nciSaceCO2High</i>	Zone CO2 level for open damper
44	<i>nciRcvHrtBt</i>	Receive heartbeat

5.3.9 Frost Protection

The frost protection is active in the forced mode “off”. If the room temperature falls below 10 °C, e.g. if a window is open, the heating is turned on. The heating is on until the temperature gets above 11,5 °C. The controller uses the setpoint 12 °C.

See Chapter 5.2.2, “Forcing the Controller”, on page 33 for operation mode when the frost protection is enabled.

5.3.10 Master/slave Operation

As the controller can control a number of slave units it is possible to control several TAC Xenta 103-A controllers within the same zone. When bit 7 in *nciAppOptions* is active (=1) the controller works as a slave, at all other times it works as master. The slave and the master controller must be of the same type.

The communicating network variables between the master controller and all slave controllers are bound according to Fig. 5.5. Apart from *nvoUnitStatus*, no other nvo’s have reliable values, and therefore they should not be bound to other units.

A TAC Xenta 103-A working as a slave controller only controls the heating, cooling valve, and the cooling damper according to the values sent by its master controller on the network. It does not take account of other inputs.

The slave controller must have the same type of heating actuator as the master, i.e. bit 6 in the variable *nciAppOptions* must be the same in both.

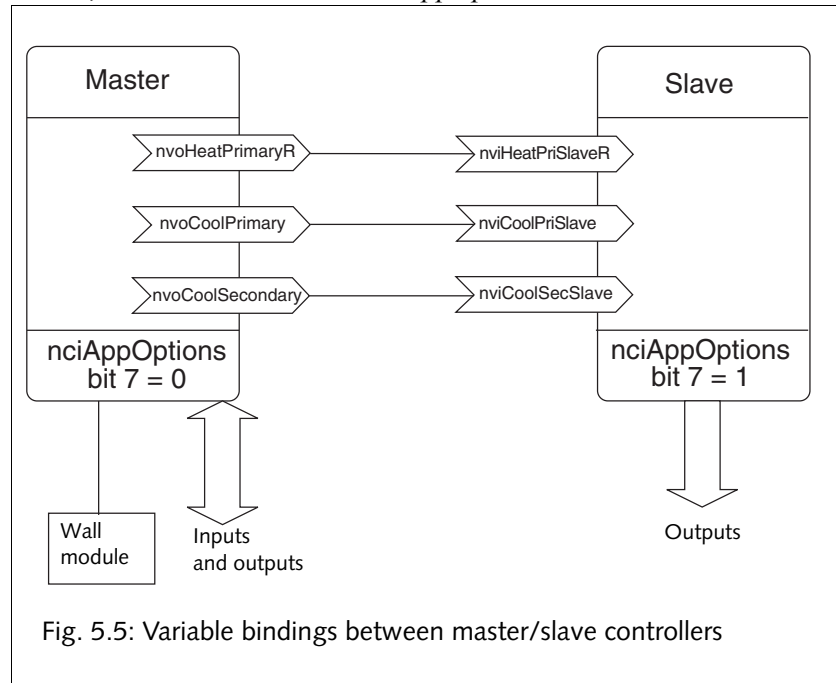

Fig. 5.5: Variable bindings between master/slave controllers

Index	Variable name	Description
2	<i>nvoUnitStatus</i>	Unit status output
7	<i>nvoHeatPrimaryR</i>	Heating control output for slave
8	<i>nvoCoolPrimary</i>	Damper position output
9	<i>nvoCoolSecondary</i>	Cooling control output
19	<i>nviHeatPriSlaveR</i>	Heating control input for slave
20	<i>nviCoolPriSlave</i>	Damper position input for slave
21	<i>nviCoolSecSlave</i>	Cooling control input for slave
22	<i>nciAppOptions</i>	Application options

6 Trouble-shooting

6.1 General

The TAC Xenta 104-A is a very reliable controller. However if problems do occur, use the trouble-shooting tips in this chapter. If you need further help, please contact your nearest TAC service point.

6.2 Inputs and Outputs (nvi/nvo's)

The most important variables for information on the current status of the controller during operation, are the *nvo*'s and the *nvi*'s. You can use these to check the controller's operation and remedy any faults or disturbances. In Chapter 8, "Communication", on page 53, you find complete information about all the variables' index, variable name, function, accepted values, normal values etc.

Index	Name	Description
1	<i>nvoEffectOccup</i>	Effective occupancy output
2	<i>nvoUnitStatus</i>	Unit status output
3	<i>nvoAlarmStatus</i>	Alarm status output
4	<i>nvoEffectSetpt</i>	Effective setpoint output
5	<i>nvoSpaceTemp</i>	Zone temperature
6	<i>nvoHeatPrimary</i>	Heating control
7	<i>nvoHeatPrimaryR</i>	Heating control for slave
8	<i>nvoCoolPrimary</i>	Damper position
9	<i>nvoCoolSecondary</i>	Cooling control
10	<i>nvoSpaceCO2</i>	Zone CO ₂ sensor
11	<i>nvoEnergyHoldOff</i>	Window contact status
12	<i>nviManOccCmd</i>	Occupancy scheduler input
13	<i>nviApplicMode</i>	Application mode input (forcing the controller)
14	<i>nviSpaceTemp</i>	Zone temperature input, replaces input B1 at a valid value
15	<i>nviSetpoint</i>	Setpoint, which at a valid value recalculates <i>nciSetpoints</i>
16	<i>nviSetpntOffset</i>	Setpoint offset
17	<i>nviSpaceCO2</i>	Zone CO ₂ input
18	<i>nviEnergyHoldOff</i>	Window contact determines operation mode together with input X3
19	<i>nviHeatPriSlaveR</i>	Heating control input for slave
20	<i>nviCoolPriSlave</i>	Damper position input for slave
21	<i>nviCoolSecSlave</i>	Cooling control input for slave
39	<i>nvoOccSensor</i>	Occupancy sensor status, only input X2 is copied
40	<i>nviOccSensor</i>	Occupancy sensor, determines operation mode together with input X2

6.3 Trouble-shooting Guide

What affects...	Check...
Operation?	<ul style="list-style-type: none"> • Bypass timer on wall module (X1). If you have pressed the bypass key, it takes 2 hours before the time expires. • Occupancy sensor (X2) or similar network variable, <i>nviOccSensor</i>. If the occupancy sensor has indicated presence, it takes 20 minutes before it is disabled. • How the content in <i>nvoEffectOccup</i> can be affected. See Section 5.2.1, “Operation Modes”, on page 31 about operation modes. • Order via network, <i>nviManOccCmd</i>.
Operation mode? (Forcing of controller)	<ul style="list-style-type: none"> • Chosen settings in <i>nciAppOptions</i> • Order via network, <i>nviApplicMode</i> • If a window contact (X3) or similar network variable, <i>nviEnergyHoldOff</i>, is enabled. • Outputs heating/cooling, <i>nvoUnitStatus</i>, <i>nvoHeatPrimary</i>, <i>nvoCoolPrimary</i>, <i>nvoCoolSecondary</i> which can be affected by normal control or <i>nciHeatPrimMin</i>.
Control setpoint?	<ul style="list-style-type: none"> • Current operation mode, <i>nvoEffectOccup</i>. • Current unit status, <i>nvoUnitStatus</i>. • Set basic setpoints, <i>nciSetpoints</i>. Controlled by options chosen in <i>nciAppOption</i> concerning calculation method A or B together with respect to <i>nviSetpoint</i>. Not a valid value in <i>nviSetpoint</i> gives the basic setpoints. See section 5.2.4 on setpoint calculation. • <i>nviSetpntOffset</i> and/or the setpoint knob on the wall module. Results in +/- influence.
Read room temperature?	<ul style="list-style-type: none"> • Physical reading (B1) or similar network variable, <i>nviSpacetemp</i>. A valid value on the network overrides a physical reading. <i>nciSpaceTempOfst</i> can displace the value.
Read carbon dioxide level?	<ul style="list-style-type: none"> • Physical input (Z1) or similar network variable <i>nciSpaceCO2</i>. When <i>nciSpaceCO2</i> has a valid value, the controller uses this.
That an alarm is set?	<ul style="list-style-type: none"> • Current values in <i>nciSpaceTempDev</i> and <i>nciSpaceTempLow</i>. • If a window is open (window contact). See Section 5.3.8, “Alarm”, on page 43.
The LED on the wall module?	<ul style="list-style-type: none"> • The controller receives power when the LED is out. • The controller when the service LED is lit. This indicates that the controller does not work correctly and should be replaced. • The controller when the service LED is lit for 15 seconds and then goes out. This is not a fault, but an indication that the controller answers a “wink” command from the network. • Current operation.

7 Technical Data

7.1 Technical Data

Power

Supply voltage		
TAC Xenta 103-A 24 V AC	-10% +20%,	50-60 Hz
Power consumption: 103-A		
Controller with TAC Xenta OP		4 VA
Power supplies for actuator		max. 12 VA
Digital outputs		max. 2x19=38 VA
Total		max. 54 VA

Ambient temperature:

Operation	0 °C – +50 °C (32 – 122 °F)
Storage	-20 °C – +50 °C (-4 – 122 °F)
Humidity	max. 90% R.H., non-condensating

Enclosure

Material	ABS/PC-plastic
Protection	IP 30
Colour	gray/red
Dimensions	122 x 126 x 50 mm (4.8 x 5 x 2 in)
Weight	0.4 kg (0.88 lb)

Input/Output

Inputs for occupancy sensor and window contact, X2-X3:

Voltage open contact	23 V DC \pm 1 V DC
Current closed contact	4 mA
Min. pulse width X2 / X3	250 ms/15 s

Temperature sensor input, B1:

Thermistor type	NTC, 1800 W at 25 °C (77 °F)
Measuring range	-10 °C – +50 °C (14 to 122 °F)
Accuracy	\pm 0.2 °C (\pm 0.4 °F)

Input, bypass key on wall module, X1:

Min. pulse width	250 ms
Max. current, LED	2 mA, for ZS 100 series

Input R1, setpoint control in wall module:

Type	10 kW linear potentiometer
Adjustment range	-5 °C – +5 °C (\pm 9 °F)
Accuracy	\pm 0,1 °C (\pm 0.2 °F)

Input Z1, carbon dioxide sensor:

Measuring range	0–10 V DC
Accuracy	\pm 0.05 V

Outputs Y1–Y2, cooling valve and cooling damper:

Output voltage range	0–10 V DC
Max. current	2 mA
Accuracy	\pm 0.2 V

Application program:

Cycle time	15 s
------------	------

LED (light emitting diode) colour:

Power supply	green
Service	red

Interoperability:

Standard

TAC Xenta 103-A Controller	LonMark Interoperability Guidelines LonMark Functional Profile: Chilled Ceiling Controller
Communication protocol	LonTalk

Physical channel	TP/FT-10, 78 kbps
Neuron type 3150 [®]	10 MHz

Conformance to standards:

Emission	EN 50081-1
Immunity	EN 50082-1
Safety	EN 61010-1
ETL listing	UL 3111-1 first version CAN/CSA C22.2 No. 1010.1-92
Flammability, integrated materials	UL 94 V-0
CE mark	complies with the demands

Part number:

TAC Xenta 103-A Controller	0-073-0561
Terminal kit, TAC Xenta 100-	0073-0914
Diskette with external interface files (XIF) for TAC Xenta 100 series	0-008-5582

7.2 Dimensions

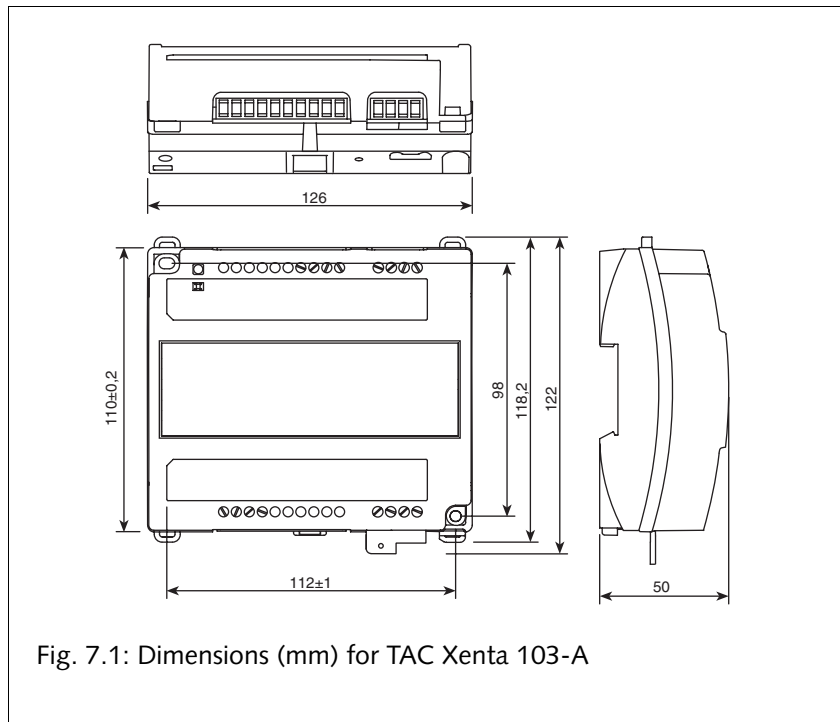

8 Communication

8.1 General

The controller consists of two LonMark objects: the node object (Chapter 8.5, “The Node Object”, on page 55) and the controller object (Chapter 8.6, “The Controller Object”, on page 56). These objects are monitored using the network variables *nviRequest* and *nvoStatus*.

The network variable *nciLocation* is used when configuring the basic parameters (Chapter 4.1, “Basic Parameters”, on page 26) to give a detailed description of the actual place where the controller is fitted. The variable receives an arbitrary string of signs and dividers as long as the string is no longer than 30 signs. You can program a specific location label, e.g.

TAMF.main.floor3.room343/RC40

A LNS based network management tool uses *nciLocation* when a data base needs to be recreated. The monitoring of an installed network is made by the LNS tool reading *nciLocation*, and then using the information to give the node a subsystem name and a unit name. The string should therefore consist of a name and a search path for the subsystem, followed by a slash and the unit name, i.e.

system.subsystem[.subsystem...]/unit name

8.2 Default Settings and Power on

For all network variables the following settings are valid:

- Number of sent messages per time unit: NONE
- Service type: NOT CONFIRMED if not stated otherwise
- Access check: NO, possible to configure: YES.
- Polled: NO for all *nvo* and *nci*, YES for all *nvi* (starting up)
- Synchronized: NO
- Change/update only when the controller is not active on the network; flags = NO
- Restart of TAC Xenta 103-A after change; flags = YES

All network variables have the same index as they have in the menu tree in the operator panel TAC Xenta OP. They represent the order in which

they have been declared in the system program; as the order is important for the variables' self documentary string. The variables are of a standard type or so called SNVT. The values that each SNVT can receive, are listed in the tables in this chapter. Apart from SNVT, there are also standard configuration parameters (SCPT) and parameter types for user configuration (UCPT). To learn more about SNVT/SCPT/UCPT see the "The SNVT Master List and Programmer's Guide" on www.lon-mark.org.

At power on, all variables for inputs and outputs (*nvi* and *nvo*) receive their default values. On a restart the configuration parameters (*nci*) retain their earlier set values. After restart every *nvi* will send a request to all the *nvo* to which they are bound (a poll).

8.3 Monitoring Network Variables, Heartbeat

The TAC Xenta 103-A has a function, called Heartbeat, which can be configured to monitor input and output variables on the network.

In the overviews in this chapter, you can see whether the variable is monitored with Heartbeat in the column Hb.

Inputs

Some of the inputs to the TAC Xenta 103-A are monitored in a way that the variable must receive values within a certain time for it to be regarded as valid. If no value is received within this time, the variable will return to its default value. An alarm will also be enabled, bit 12 in *nvoAlarmStatus*.

Which inputs are monitored in this way, you find in the list of network variables in Chapter 8.6.1, "The Controller Object's Inputs (*nvi*)", on page 59.

The time is set with the variable *nciRcvHrtBt*. Its default value is 0.0, which means that no monitoring is performed.

Outputs

The bound outputs are normally sent out when they are changed. Most outputs of the TAC Xenta 103-A are monitored, so even if the values are not changed, they are sent out at even intervals.

Which outputs are monitored in this way, you find in the list of network variables in Chapter 8.6.2, "The Controller Object's Outputs (*nvo*)", on page 60.

The time is set with the variable *nciSndHrtBt*. Its normal value is 0.0, which means that no monitoring is performed.

8.4 Not Accepted Values

All *nvo* are limited to their accepted values, and all *nvi* detect whether the incoming value is within the accepted limits. If the value is not accepted, the controller activates bit 13 in the variable for alarm handling, *nvoAlarmStatus*. For a *nvi*, the controller uses the off value, which is also counted as an accepted value.

8.5 The Node Object

The variables in the node object (Fig. 8.1) are divided into three categories:

- Mandatory (M)
- Optional (O)
- Configuration properties (C)

The category “Mandatory” contains all compulsory variables¹, “Optional” contains selectable variables, and “Configuration properties” contains the configuration parameters.

Note! The network variables’ indices are not the same as the figure in “nv” in the figure.

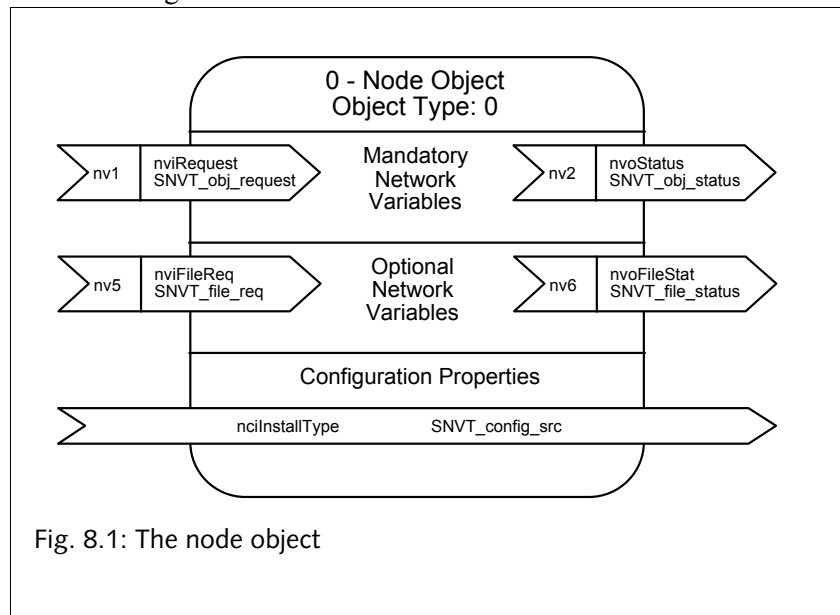

Fig. 8.1: The node object

1. According to LonMark standardised function profil for chilled ceiling controllers

8.5.1 The Node Object's Inputs (nvi)

Table 8.1: The node object's inputs (nvi)

Index	Variable	Hb ^a	SNVT	Accepted values (Service type)	Default value	Description (self doc. string)
45	<i>nviRequest</i>	No	SNVT_obj_request	0=RQ_NORMAL 2=RQ_UPDATE_STATUS 5=RQ_REPORT_MASK	RQ_NUL (Confirmed)	Object request @0 1
47	<i>nviFileReq</i>	No	SNVT_file_req	see "SNVT Master List"	FR_NUL (Confirmed)	File request @0 5

a. Hb=Heartbeat

8.5.2 The Node Object's Outputs (nvo)

Table 8.2: The node object's outputs (nvo)

Index	Variable	Hb ^a	SNVT	Accepted values (Service type)	Default value	Description (self doc. string)
46	<i>nvoStatus</i>	No	SNVT_obj_status	invalid_id (0..1) invalid_request(0..1)	Alla = 0 (Confirmed)	Object status @0 2
48	<i>nvoFileStat</i>	Yes	SNVT_file_status	see "SNVT Master List"	FS_NUL (Confirmed)	File status @0 6

a. Hb=Heartbeat

8.5.3 The Node Object's Configuration Parameters (nci)

Table 8.3: The node object's configuration parameters (nci)

Index	Variable	Hb ^a	SNVT SCPT/UCPT	Accepted values	Default value	Description (self doc. string)
42	<i>nciInstallType</i>	No	SNVT_config_src SNVT_config_src (25)	0=CFG_LOCAL 1=CFG_EXTERNAL CFG_NUL	0=CFG_LOCAL	Network configuration source &0,,0x80,25

a. Hb=Heartbeat

8.6 The Controller Object

The variables in the controller object (figure 8.2) are divided into four categories:

- Mandatory (M)
- Optional (O)
- Configuration properties (C)
- Manufacturer Defined Section (MDS)

The category "Mandatory" contains all compulsory variables¹, "Optional" contains selectable variables, "Configuration properties"

1. According to LonMark standardised function profile for chilled ceiling controllers

contains configuration parameters, and “Manufacturer Defined Section” includes all other variables that make the controller’s functions possible.

Note! The network variables' indexes are not the same as the figure in "nv" in the diagram below.

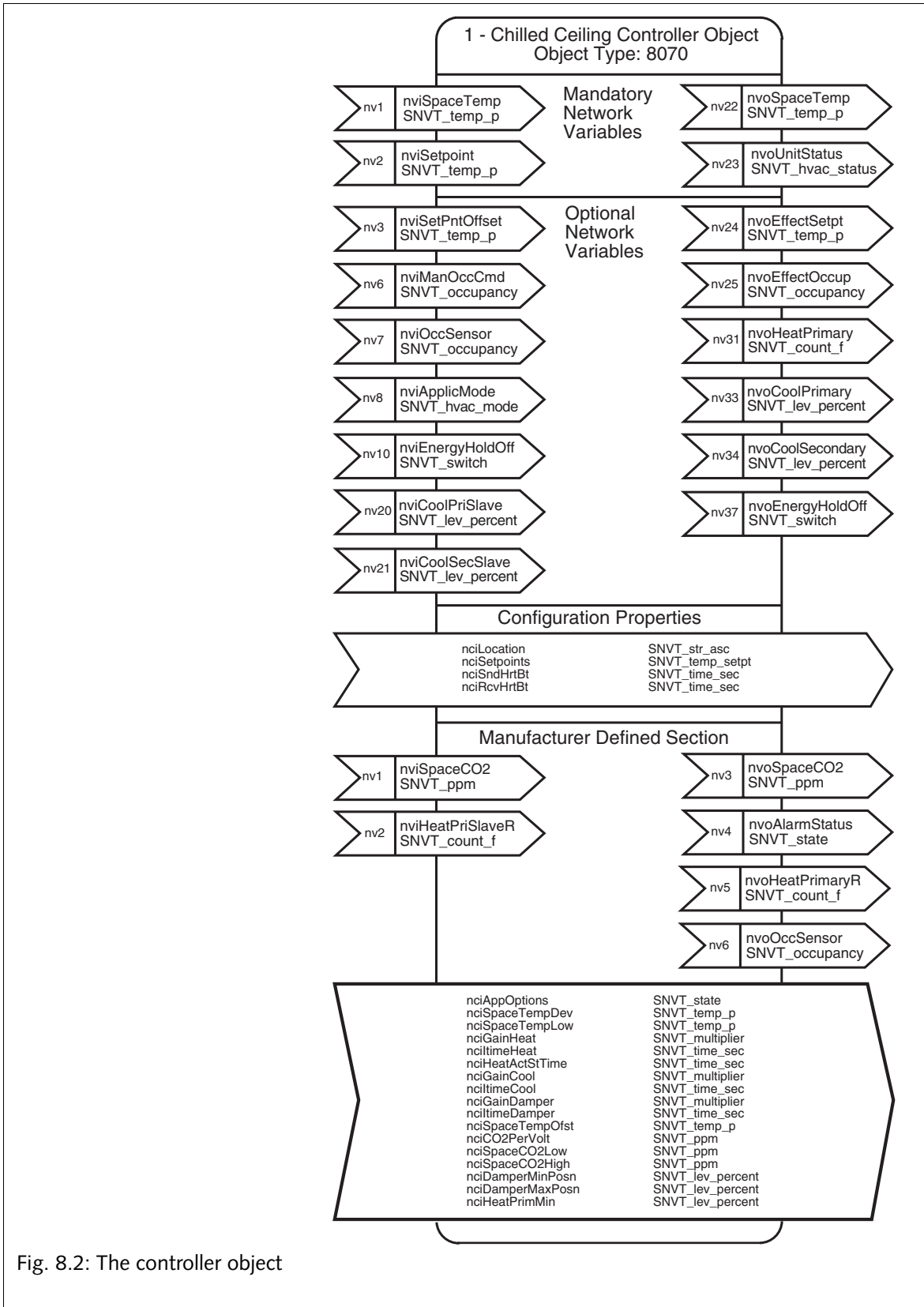

Fig. 8.2: The controller object

8.6.1 The Controller Object's Inputs (nvi)

Table 8.4: The controller object's inputs (nvi)

Index	Variable	Hb ^a	SNVT	Accepted values	Default value	Description (Self doc. string)
12	<i>nviManOccCmd</i>	No	SNVT_occupancy	0=OC_OCCUPIED 1=OC_UNOCCUPIED 3=OC_STANDBY other values=OC_NUL	OC_NUL	Occupancy scheduler input @1 6
13	<i>nviApplicMode</i>	Yes	SNVT_hvac_mode 1=HVAC_HEAT	0=HVAC_AUTO 3=HVAC_COOL 4=HVAC_NIGHT_PURGE 6=HVAC_OFF; other 6=HVAC_OFF; other	HVAC_AUTO	Application mode input @1 8
14	<i>nviSpaceTemp</i>	Yes	SNVT_temp_p 327,67 °C ^b	-10 °C to 50 °C	327,67 °C ^b	Zone temperature input, @1 1
15	<i>nviSetpoint</i>	No	SNVT_temp_p 327, 67 °C ^b	10 °C to 35 °C,	327,67 °C ^b	Temperature setpoint input, @1 2
16	<i>nviSetpntOffset</i>	Yes	SNVT_temp_p	-10 °C to 10 °C	0 °C	Setpoint offset input, @1 3
17	<i>nviSpaceCO2</i>	Yes	SNVT_ppm 65535 ^b	0 to 5000 ppm	65535 ppm ^b	Zone CO ₂ input @1#1
18	<i>nviEnergyHoldOff</i>	Yes	SNVT_switch	0 (off) to 1 (to), 0% to 100%	0 (off), 0%	Energy hold off input Enabled when the variable is 1 (to) and the value ≠ 0%, @1 10
19	<i>nviHeatPriSlaveR</i>	Yes	SNVT_count_f	-50 to 50	0	Heating control input for slave, @1#2
20	<i>nviCoolPriSlave</i>	Yes	SNVT_lev_percent	0% to 100%	0%	Damper position input for slave, @1 20
21	<i>nviCoolSecSlave</i>	Yes	SNVT_lev_percent	0% to 100%	0%	Cooling control input for slave, @1 21
40	<i>nviOccSensor</i>	Yes	SNVT_occupancy	0=OC_OCCUPIED 1=OC_UNOCCUPIED other values=OC_NUL	OC_NUL	Occupancy sensor input, @1 7

a. Heartbeat

b. Off value

8.6.2 The Controller Object's Outputs (nvo)

Table 8.5: The Controller Object's Outputs (nvo)

Index	Variable	Hb ^a	SNVT	Accepted values	Default value	Description (Self doc. string)
1	<i>nvoEffectOccup</i>	Yes	SNVT_occupancy	OC_OCCUPIED OC_UNOCCUPIED OC_BYPASS OC_STANDBY	OC_OCCUPIED	Effective occupancy output @1 25
2	<i>nvoUnitStatus</i>	Yes	SNVT_hvac_status mode	HVAC_HEAT HVAC_COOL HVAC_NIGHT_PURGE HVAC_OFF	HVAC_HEAT	Unit status output @1 23
			heat_output_primary	0% to 100%, 163,83% ^b	163,83% ^b	
			heat_output_secondary	163,83% ^b	163,83% ^b	
			cool_output	0% to 100%, 163,83% ^b	163,83% ^b	
			econ_output fan_output	163,83% ^b 0% to 100%,	163,83% ^b 163,83% ^b	
			(damper pos.) in_alarm	163,83% ^b	255 ^b	
3	<i>nvoAlarmStatus</i>	No	SNVT_state	16 bits, 0 =normal, 1 = alarm	00000000 00000000	Alarm status output @1#4
4	<i>nvoEffectSetpt</i>	Yes	SNVT_temp_p	10 °C to 35 °C	occupied_heat	Effective setpoint output @1 24
5	<i>nvoSpaceTemp</i>	Yes	SNVT_temp_p 327,67 °C ^b	-10 °C to 50 °C,	327,67 °C ^b	Zone temperature output, @1 22
6	<i>nvoHeatPrimary</i>	Yes	SNVT_lev_percent 163,83% ^b	0% to 100%,	163,83% ^b	Heating control output @1 31
7	<i>nvoHeatPrimaryR</i>	Yes	SNVT_count_f	-50 to 50	0	Heating control output for slave, @1#5
8	<i>nvoCoolPrimary</i>	Yes	SNVT_lev_percent 163,83% ^b	0% to 100%,	163,83% ^b	Damper position output, @1 33
9	<i>nvoCoolSecondary</i>	Yes	SNVT_lev_percent 163,83% ^b	0% to 100%,	163,83% ^b	Cooling control output @1 34
10	<i>nvoSpaceCO2</i>	Yes	SNVT_ppm	0 to 5000 ppm	Input Z1, nciCO2PerVolt	Zone CO ₂ sensor output, @1#3
11	<i>nvoEnergyHoldOff</i>	Yes	SNVT_switch	0 (off) to 1 (on), 0% to 100%	0 (off), 0%	Energy hold off output 0 (off), 0% and 1 (on), 100%, @1 37
39	<i>nvoOccSensor</i>	Yes	SNVT_occupancy	0=OC_OCCUPIED 1=OC_UNOCCUPIED other values=OC_NUL	OC_NUL	Occupancy sensor output, @1#6

a. Hb = Heartbeat

b. Off value

8.6.3 The Controller Object's Configuration Parameters (nci)

Table 8.6: The Controller Object's Configuration Parameters (nci)

Index	Variable	Hb ^a	SNVT SCPT/UCPT	Accepted values	Default value	Description (Self doc. string)
0	<i>nciLocation</i>	No	SNVT_str_asc SCPT_location (17)	31 ASCII characters	All = 0	Location label &1,1,0x80,17
22	<i>nciAppOptions</i>	No	SNVT_state UCPT (1)	16 bits, 0–1	00000000 00000000	Application options &1,1,3x8A,1
23	<i>nciSetpoints</i>	No	SNVT_temp_setpt SCPTsetPnts (60)	10 °C to 35 °C	occ cool = 23 °C stby cool = 25 °C unoc cool = 28 °C occ heat = 21 °C stby heat = 19 °C unoc heat = 16 °C	Occupancy temperature setpoints &1,1,0x80,60, 10:35 10:35 10:35 10:35 10:35 10:35
24	<i>nciSpaceTempDev</i>	No	SNVT_temp_p UCPT (16)	0 °C to 10 °C	2 °C	Max. deviation of zone temperature &1,1,3x80,16,0:10
25	<i>nciSpaceTempLow</i>	No	SNVT_temp_p UCPT (17)	0 °C to 20 °C	10 °C	Low limit of zone temp. &1,1,3x80,17,0:20
26	<i>nciGainHeat</i>	No	SNVT_multiplier UCPT (2)	0 to 32,7675	25	Gain for heat. controller &1,1,3x80,2
27	<i>ncitimeHeat</i>	No	SNVT_time_sec UCPT (3)	0 s to 3600 s = 60 minutes	1500 s = 25 minutes	Integral time for heating controller &1,1,3x80,3,0:3600
28	<i>nciHeatActStTime</i>	No	SNVT_time_sec UCPT (4)	5 s to 600 s	165 s	Stroke time for heating actuator &1,1,3x80,4,5:600
29	<i>nciGainCool</i>	No	SNVT_multiplier UCPT (5)	0 to 32,7675	25	Gain for cool. controller &1,1,3x80,5
30	<i>ncitimeCool</i>	No	SNVT_time_sec UCPT (6)	0 s to 3600 s =60 minutes	900 s = 15 minutes	Integral time for cooling controller &1,1,3x80,6,0:3600
31	<i>nciGainDamper</i>	No	SNVT_multiplier UCPT (7)	0 to 32,7675	25	Gain for damper control &1,1,3x80,7
32	<i>ncitimeDamper</i>	No	SNVT_time_sec UCPT (8)	0 s to 3600 s = 60 minutes	900 s = 15 minutes	Integr. time damp. contr. &1,1,3x80,8,0:3600
33	<i>nciSpaceTempOfst</i>	No	SNVT_temp_p UCPT (20)	–10,0 °C to 10,0 °C	0,0 °C	Zone temperature sensor adjustment &2,14,3x80,20,– 10.0:10.0
34	<i>nciCO2PerVolt</i>	No	SNVT_ppm UCPT (9)	0 to 2500 ppm CO ₂ per volt	200 ppm CO ₂ per volt	Conversion factor ppm CO ₂ per volt &1,1,3x80,9,0:2500
35	<i>nciSpaceCO2Low</i>	No	SNVT_ppm UCPT (10)	0 to 1000 ppm	400 ppm	Zone CO ₂ level for closed damper &1,1,3x80,10,0:1000
36	<i>nciSpaceCO2High</i>	No	SNVT_ppm UCPT (11)	0 to 2000 ppm	1000 ppm	Zone CO ₂ level for open damper &1,1,3x80,11,0:1000
37	<i>nciDamperMinPosn</i>	No	SNVT_lev_percent UCPT (21)	0% to 100%	30%	Air damper min. pos. &2,8,3x80,21,0:100
38	<i>nciDamperMaxPosn</i>	No	SNVT_lev_percent UCPT (22)	0% to 100%	100%	Air damper max. pos. &2,8,3x80,22,0:100
41	<i>nciHeatPrimMin</i>	No	SNVT_lev_percent	0% to 100%	0%	Min. output heat. contr. &1,1,3x80,23,0:100
43	<i>nciSndHrtBt</i>	No	SNVT_time_sec SCPTmaxSendTime (49)	5,0 s to 6553,4 s 0,0 s = disabled	0,0 s (disabled)	Send heartbeat &2,1,2.4.5.6.7.8.9.10.11 .39,0x8A,49
44	<i>nciRcvHrtBt</i>	No	SNVT_time_sec SCPTmaxSendTime (48)	0,0 s to 6553,4 s 0,0 s = disabled	0,0 s (disabled)	Receive heartbeat &2,13.14.16.17.18.19. 20.21.40,0x8A,48

a. Hb=Heartbeat

APPENDIX

A Setpoint Calculation

A Setpoint Calculation

Definitions:	
Deadband	= Neutral zone
Occupied	= Comfort mode
Standby	= Economy mode
Unoccupied	= Off mode
nviSetPoint	= Input temperature setpoint (<i>nviSetpoint</i>)
nciSetPoints	= Six basic setpoints for temperature (<i>nciSetpoints</i>)
Occupied_cool	= Cooling setpoint comfort
Standby_cool	= Cooling setpoint economy
Unoccupied_cool	= Cooling setpoint off
Occupied_heat	= Heating setpoint comfort
Standby_heat	= Heating setpoint economy
Unoccupied_heat	= Heating setpoint off
Effective	= Existing

In *nciSetpoints*, the cooling and heating setpoints for comfort and economy mode are set. *nviSetpoint* allows you to move all four setpoints with only one value. The mean value of the comfort setpoints in *nciSetpoints* can be seen as the basic setpoint for comfort mode, and the mean value of the economy setpoints can be seen as the basic setpoint for economy mode. The temperature scale for the setpoints must be as follows:

$$unoccupied_heat \leq standby_heat \leq occupied_heat \leq occupied_cool \leq standby_cool \leq unoccupied_cool.$$

There are two methods to calculate the setpoints:

- Method A
- Method B

Method A:

When *nviSetpoint* receives a valid setpoint, this value becomes the new, common setpoint. The cooling and heating setpoints are recalculated to be at the same distance from the new, basic setpoint as they were from the previous basic setpoint. Therefore, method A removes the existing asymmetry (see the example on the next page).

The controller calculates the different setpoints for heating and cooling in comfort and economy mode, from *nviSetpoint*, plus or minus half the neutral zone in the comfort and economy modes. These are calculated from the *nciSetpoints*. The controller takes the two heating and cooling setpoints in off mode from *nciSetpoints*.

$$deadband_occupied = occupied_cool - occupied_heat$$

$$deadband_standby = standby_cool - standby_heat$$

$$effective_occupied_cool = nviSetPoint + 0,5 (deadband_occupied)$$

$$effective_occupied_heat = nviSetPoint - 0,5 (deadband_occupied)$$

$$effective_standby_cool = nviSetPoint + 0,5 (deadband_standby)$$

$$effective_standby_heat = nviSetPoint - 0,5 (deadband_standby)$$

Method B:

In economy mode you can chose method B to calculate the existing setpoints. In this case, the setpoints' distance from the existing setpoint, is the same as the distance they had from the old, basic setpoint in comfort mode. Method B only works when the two setpoints from *nciSetpoints* do not have have different values, that is, when the four setpoints are not placed symmetrically around one value. With Method B the asymmetry is kept, as the old comfort setpoint is used (see the example on the next page).

The controller calculates the different setpoints for heating and cooling in comfort and economy modes from *nciSetpoints* and the actual absolute setpoint deviation is calculated as the mean value of the *occupied_heat* setpoint and the *occupied_cool* setpoint. The controller gets the different heating and cooling setpoints in off mode from *nciSetpoints*.

$$effect_abs_setpoint_offset = nviSetpoint - (occupied_cool + occupied_heat) / 2$$

$$effective_occupied_cool = occupied_cool + effect_abs_setpoint_offset$$

$$effective_occupied_heat = occupied_heat + effect_abs_setpoint_offset$$

$$effective_standby_cool = standby_cool + effect_abs_setpoint_offset$$

$$effective_standby_heat = standby_heat + effect_abs_setpoint_offset$$

The following two examples show how *nviSetpoint* works and Method A and B.

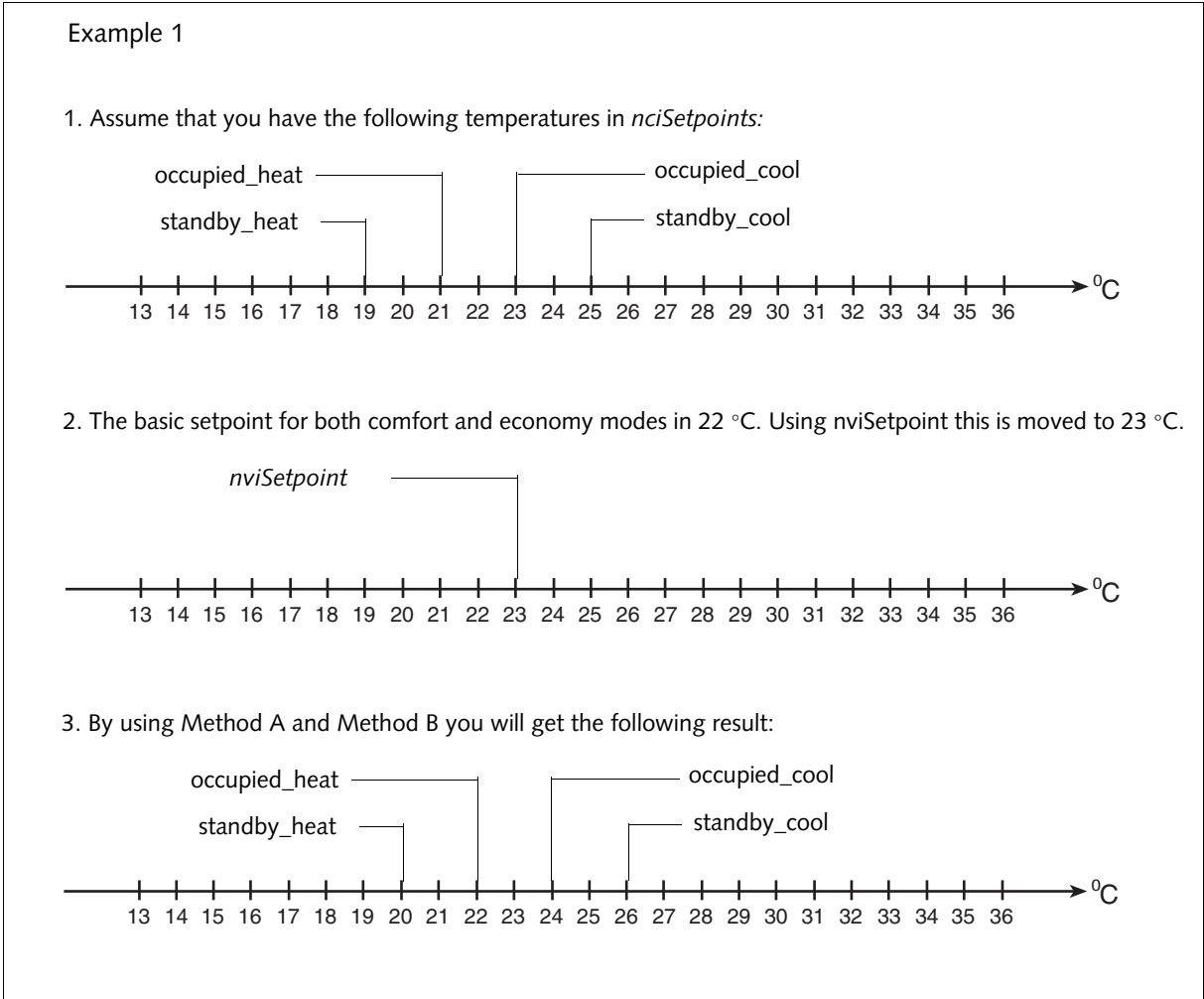

Example 2

1. Assume that you have the following temperatures in *nciSetpoints*:

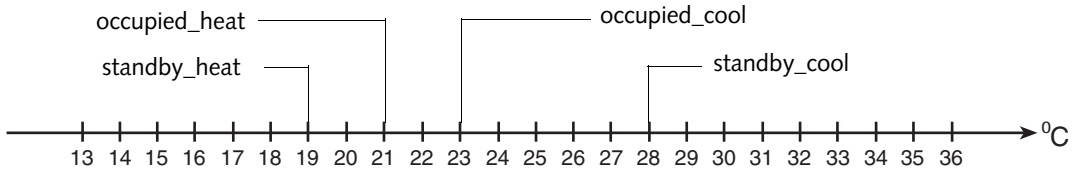

2. You can allow up to 29 °C before you start cooling in economy mode with *nviSetpoint*. The basic setpoint for comfort is 22 C and for economy 24 °C.

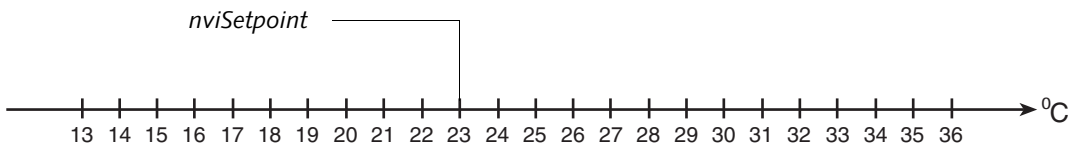

3a. Results achieved using Method A:

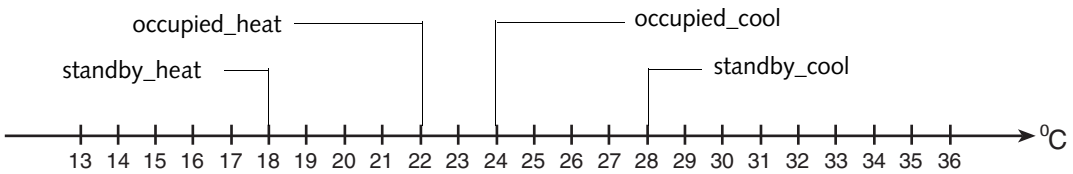

3b. Results achieved using Method B:

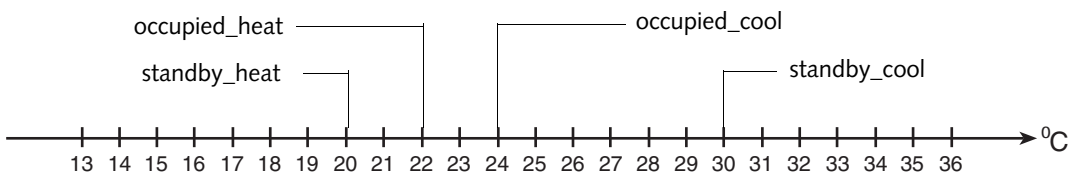

B Commissioning Protocol

This protocol can be used when commissioning the Fan Coil controller TAC Xenta 103-A. Note that the indices are listed in numerical order, not in the order they are accessed during commissioning. To find information about accepted values see the tables in chapter 8.

Table B.1: Commissioning Protocol

Index	Function	Variable	Default value	Set value	Note
0	Location label	nciLocation	0		
12	Occupancy scheduler input	nviManOccCmd	OC_NUL		
13	Application mode input	nviApplicMode	0=Auto		
14	Zone temperature input	nviSpaceTemp	327,67 °C		
15	Temperature setpoint input	nviSetpoint	327,67 °C		
16	Setpoint offset input	nviSetpntOffset	0 °C		
17	Zone CO ₂ input	nviSpaceCO2	65536 ppm		
18	Energy hold off input	nviEnergyHoldOff	0=Off, 0 %		
19	Heating control input for slave	nviHeatPriSlaveR	0		
20	Damper position input for slave	nviCoolPriSlaveR	0		
21	Cooling control input for slave	nviCoolSecSlave	0		
22	Application options	nciAppOptions	00000000		
23	Occupancy temperature setpoints	nciSetpoints			
	(Cooling setpoint comfort occupied_cool	occupied_cool	23 °C)		
	(Cooling setpoint economy standby_cool	standby_cool	25 °C)		
	(Cooling setpoint off unoccupied_cool	unoccupied_cool	28 °C)		
	(Heating setpoint comfort occupied_heat	occupied_heat	21 °C)		
	(Heating setpoint economy standby_heat	standby_heat	19 °C)		
	(Heating setpoint off unoccupied_heat	unoccupied_heat	16 °C)		
24	Max. deviation of zone temp.	nciSpaceTempDev	2 °C		
25	Low limit of zone temperature	nciSpaceTempLow	10 °C		
26	Gain for heating controller	nciGainHeat	25		

Table B.1: Commissioning Protocol

Index	Function	Variable	Default value	Set value	Note
27	Integral time for heating controller	nciItimeHeat	1500 s		
28	Stroke time for heating actuator	nciHeatActStTime	165 s		
29	Gain for cooling controller	nciGainCool	25		
30	Integral time for cooling controller	nciItimeCool	900 s		
31	Gain for damper controller	nciGainDamper	25		
32	Integral time for damper controller	nciItimeDamper	900 s		
33	Zone temp. sensor adjustment	nciSpaceTempOfst	0,0 °C		
34	Conv. factor ppm CO ₂ per volt	nciCO2PerVolt	200 ppm/V		
35	Zone CO ₂ level for closed damper	nciSpaceCO2Low	400 ppm		
36	Zone CO ₂ level for open damper	nciSpaceCO2High	1000 ppm		
37	Air damper min. position	nciDamperMinPosn	30%		
38	Air damper max. position	nciDamperMaxPosn	100%		
40	Occupancy sensor input	nviOccSensor	OC_NUL		
41	Minimum output heating controller	nciHeatPrimMin	0%		
42	Network configuration source	nciInstallType	0=LOCAL		
43	Send heartbeat	nciSndHrtBt	0,0 s		
44	Receive heartbeat	nciRcvHrtBt	0,0 s		
45	Object request	nviRequest	RQ_NUL		
47	File request	nviFileReq	FR_NUL		

Index

A

alarm 43
application 15

B

basic parameters 26
bypass mode 33

C

cables 19
calculation 35
comfort mode 32
commissioning 22
commissioning protocol 69
communication 53
configuration parameters 25
connection terminals 20
control sequence 37

D

DIN rail 17
documentation, additional 7

E

economy mode 32
electrical installation 18

F

force the controller 34
frost protection 44
functional description 31

I

inputs and outputs (nvi/nvo's) 47
installation 17
Installation, network 23

L

LNS 8
LonWork® Network Services 8

M

master/slave operation 44
measuring zone temperature 34
mechanical installation 17
minimum value for heating valve 42
Modes, operation, comfort, economy, bypass, off 31

N

nciAppOptions 26
nciRcvHrtBt 29
nciSndHrtBt 29
network installation 23
neuron 8
node 8

O

off mode 33
operation modes 31

P

parameter, basic 26
parameters, other configuration 27

S

safety standard 19
setpoint 34

W

wall module configuration 14
wink 8
wiring 21

www.tac.com

TAC helps people feel and function better, as a direct result of greater indoor climate. This is made possible by TAC's concept of Open Systems for Building IT[®], which utilizes information technology to provide clients with advantages such as indoor climate optimization, energy savings, flexibility, security, reduced expenses and user-friendly operation.

