



## Heating Controller

**RVP331**

for 2 heating circuits, d.h.w. and boiler

- **Multi-functional heating controller for use in residential and non-residential buildings**
- **Suitable for weather-compensated flow temperature control of 2 heating zones with or without room temperature influence and, at the same time, demand-compensated boiler temperature control**
- **Control of d.h.w. heating**
- **6 preprogrammed plant types with automatic assignment of the functions required for each type of plant**
- **Digital setting of the heating curve, analog room temperature readjustment, operating line principle for all other parameters**
- **Multi-functional relay**
- **Operating voltage AC 230 V, CE conformity**

### Use

- **Types of buildings:**
  - Multi-family houses
  - Single-family houses
  - Smaller non-residential buildings
- **Types of plants:**
  - Heating zones and d.h.w. heating plants
- **Types of heating systems:**
  - Radiator, convector, underfloor and ceiling heating systems, radiant panels

## Functions

---

**Heating zone controls** Weather-compensated flow temperature control through control of the seat or slipper valve and demand-compensated control of the boiler temperature through control of the burner.

**D.h.w. control**

- D.h.w. heating through control of the charging pump
- Control of a circulating pump or of an electric immersion heater

### Operating modes



#### Automatic mode

Automatic changeover from normal to reduced temperature, and vice versa, according to the 7-day program, automatic changeover to holiday mode, demand-dependent control of the heating system (ECO function)



#### Setback mode

Continuous heating to the reduced temperature, with ECO function



#### Comfort mode

Continuous heating to the normal temperature, no ECO function



#### Standby



#### Automatic d.h.w. heating

Frost protection is ensured in all operating modes.

The controller can be switched to manual operation.

### Other functions

- Optimization functions
- Protective functions
- Remote control
- Commissioning aids
- Room temperature acquisition (averaging, automatic selection room unit / room sensor)

## Ordering

---

When ordering, please give type reference **RVP331** and the language code letter (-A, -B or -C) for the Operating Instructions and the Installation Instructions in the requested language:

**-A** for English, French, Italian, German (e.g. RVP331-A for English)

**-B** for French, Dutch, Spanish (e.g. RVP331-B for French)

**-C** for Greek (RVP331-C)

Sensors, room unit, actuators and valves must be ordered as separate items.

## Equipment combinations

---

### Suitable sensors and room units

- Flow, return and d.h.w. temperature: all sensors with LG-Ni 1000  $\Omega$  at 0 °C, for example:
  - Strap-on temperature sensor QAD22
  - Immersion temperature sensors QAE212... or QAP21.3
- Room temperature:
  - Room unit QAW50 for heating circuit 1, QAW50.03 for heating circuits 1 and 2
  - Room unit QAW70 for heating circuits 1 and 2
  - Room temperature sensor QAA24 (Ni sensing element)
- Outside temperature:
  - Outside sensor QAC22 (Ni sensing element)
  - Outside sensor QAC32 (NTC sensing element)

## Suitable actuators

The following actuators made by SBT HVAC Products can be used:

- For 3-position control, running time 0.5...14.5 minutes
- For 2-position control
- Operating voltage AC 24 V ... 230 V

## Technical design

### Plant types

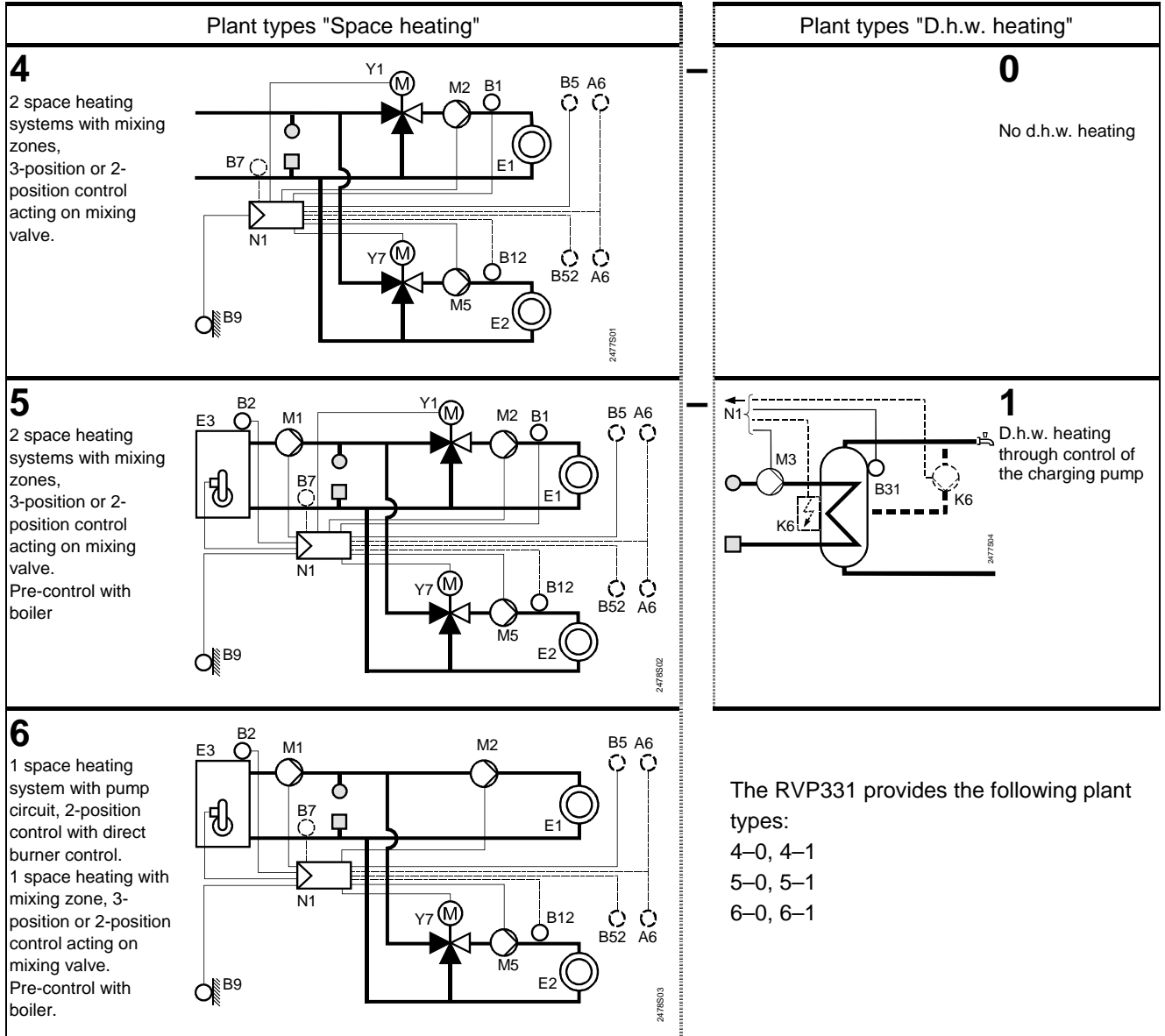

- |     |   |
|-----|---|
| A6  | Room unit QAW50... or QAW70                     |
| B1  | Flow sensor, heating circuit 1                  |
| B12 | Flow sensor, heating circuit 2                  |
| B2  | Boiler sensor                                   |
| B31 | D.h.w. storage tank sensor / control thermostat |
| B5  | Room sensor, heating circuit 1                  |
| B52 | Room sensor, heating circuit 2                  |
| B7  | Return sensor                                   |
| B9  | Outside sensor                                  |
| E1  | Load (room 1)                                   |

- |    |  |
|----|--|
| E2 | Load (room 2)                                |
| E3 | Heat source (boiler)                         |
| K6 | Electric immersion heater / circulating pump |
| M1 | Circulating pump                             |
| M2 | Heating circuit pump, heating circuit 1      |
| M3 | Charging pump                                |
| M5 | Heating circuit pump, heating circuit 2      |
| N1 | Controller RVP331                            |
| Y1 | Seat or slipper valve, heating circuit 1     |
| Y7 | Seat or slipper valve, heating circuit 2     |

<b>Working principle</b>	<p>The RVP331 offers 6 different plant types that are ready programmed in the controller. When commissioning the system, the respective plant type must be entered. This activates all functions that are required for the selected plant type. The standard settings are practice-oriented.</p> <p>All functions not required for the selected plant type will not be shown and are disabled.</p>
<b>End-user settings</b>	<p>With weather-compensated control, the flow temperature is controlled as a function of the prevailing outside temperature via the heating curve. Its basic setting is made on 2 operating lines. The room temperature can be readjusted with the knob.</p> <ul style="list-style-type: none"> <li>• Heating circuit-independent entries by the end-user: <ul style="list-style-type: none"> <li>– Operating mode d.h.w. heating</li> <li>– D.h.w. temperature setpoint</li> <li>– 7-day switching program for d.h.w. heating</li> <li>– Time of day and date</li> </ul> </li> <li>• Entries the end-user can make for each heating circuit: <ul style="list-style-type: none"> <li>– Operating mode heating circuit</li> <li>– Room temperature setpoints for normal heating, reduced heating and frost protection/holidays</li> <li>– One 7-day switching program and one holiday period per year</li> <li>– Room temperature readjustment (knob)</li> </ul> </li> </ul>
<b>Temperature acquisition</b>	<ul style="list-style-type: none"> <li>• Outside temperature: with Ni or NTC sensor; the RVP331 identifies the type of sensor used.</li> <li>• Room temperature: with a room temperature sensor or a room unit or both (averaging). The selection of room unit/room temperature sensor is made automatically.</li> </ul>
<b>Space heating</b>	<ul style="list-style-type: none"> <li>• The room temperature is included in the control. It can be acquired with a sensor or simulated by a room model with an adjustable building time constant. When using a sensor, the effect on the control can be adjusted. It is also possible to limit the maximum room temperature.</li> <li>• The heating is switched on and off depending on demand (ECO function). It is switched off when the amount of heat stored by the building mass is sufficient to maintain the required room temperature. In that case, the controller takes into account the development of the room temperature and the building's heat storage capacity. It is possible to set 2 heating limits, one for normal heating and one for reduced heating.</li> <li>• The control is optimized. Switching on, heating up and shutting down are controlled such that, during occupancy times, the required room temperature is always maintained. At the end of each occupancy period, the heating will be shut down (circulating pump) until the room temperature setpoint for the non-occupancy time is reached (quick setback, can be disabled). During heating up, the room temperature setpoint can be boosted (boost heating). It is possible to set maximum limits for the heating up time and for early shutdown.</li> </ul>
<b>Control</b>	
Heating zone with regulating unit	<p>The heating zone control operates as weather-compensated flow temperature control with 3-position or 2-position control. The flow temperature is controlled via the regulating unit (seat or slipper valve).</p> <p>Minimum and maximum limitation of the flow temperature as well as maximum limitation of the rate of setpoint increase are adjustable.</p>
Heating zone without regulating unit	<p>The heating zone control operates as weather-compensated flow temperature control. The flow temperature is controlled through direct boiler control. Minimum and maximum limitation of the flow temperature as well as overtemperature protection are adjustable.</p>

<b>Boiler control</b>	<p>The boiler temperature control operates as demand-compensated 2-position control. The boiler temperature is controlled through cycling of the single- or 2-stage burner (direct burner control). 2-stage operation is enabled when the release limit is reached, and disabled when the reset limit is reached. The limits can be adjusted.</p> <p>When there is no demand for heat, the boiler will either be shut down or maintained at the minimum temperature limit (selectable). Both minimum and maximum limitation of the boiler temperature are adjustable.</p>
<b>Minimum limitation of the return temperature</b>	<p>Minimum limitation of the return temperature helps prevent flue gas condensation.</p>
<b>Locking functions</b>	<p>On the software side, all settings can be locked to prevent unauthorized readjustments.</p>
<b>Time switch</b>	<ul style="list-style-type: none"> <li>• The RVP331 has 3 independent 7-day time switches. Each 7-day time switch affords 3 24-hour on periods, which may differ from one weekday to the other</li> <li>• For entering a holiday period per heating circuit, the RVP331 is equipped with a yearly time switch featuring automatic summer- / wintertime changeover</li> </ul>
<b>D.h.w. heating</b>	<p>D.h.w. heating is controlled independent of the heating circuits. It can be enabled:</p> <ul style="list-style-type: none"> <li>• According to its own 7-day program</li> <li>• According to the switching program of both heating circuits (one hour before space heating starts)</li> <li>• Permanently (24 hours a day)</li> </ul> <p>D.h.w. heating features a legionella function which can be deactivated. Legionella protection is provided once a week. The d.h.w. temperature is acquired with a sensor or a thermostat. D.h.w. control also includes the control of a circulating pump and an electric immersion heater (control via the multi-functional relay). The d.h.w. storage tank can be forcedly charged once a day.</p>
<b>Remote control</b>	<ul style="list-style-type: none"> <li>• Changeover of operating mode with the QAW50... room unit</li> <li>• Overriding the major controller functions with the QAW70 room unit</li> </ul>
<b>Communication</b>	<p>Communication with other devices is not possible.</p>
<b>Fault status signals</b>	<ul style="list-style-type: none"> <li>• Fault status signal in the event of sensor faults</li> <li>• Fault status signal in the event of room unit faults</li> </ul>
<b>Other functions</b>	<ul style="list-style-type: none"> <li>• Multi-functional relay. Choice of functions: <ul style="list-style-type: none"> <li>– Alarm contact in the event of fault status signals</li> <li>– On / off according to heat demand</li> <li>– Control of the d.h.w. circulating pump</li> <li>– Control of the electric immersion heater</li> </ul> </li> <li>• Display of parameters, actual values, operational statuses and fault status signals</li> <li>• Simulation of the outside temperature</li> <li>• Relay test; all relays can be controlled manually</li> <li>• Sensor test; all measured values of the sensors can be displayed</li> <li>• Outside temperature-dependent frost protection for the plant; a minimum flow temperature is maintained, its setpoint and the response threshold can be adjusted</li> <li>• Pump overrun time to prevent the buildup of heat</li> <li>• Periodic pump run (pump kick) to prevent seizing of the pump in the summer</li> <li>• Controller hours run meter</li> </ul> <p>For more detailed information about technical features and functions, please refer to the Basic Documentation P2478.</p>

The RVP331 is comprised of controller insert, which accommodates the electronics, the power section, the output relays and – on the front – all operating elements, and the base, which carries the connection terminals. The operating elements are located behind a cover.

The operating instructions are inserted in the cover.

The controller insert is secured to the base with 2 screws.

The RVP331 can be fitted in 3 different ways:

- Wall mounting (on a wall, in the control panel, etc.)
- Rail mounting (on a standard DIN mounting rail)
- Flush panel mounting (control panel door, etc.)

**Analog operating elements**

- Buttons for selecting the required operating mode
- Button for selecting the heating circuit
- Button for d.h.w. heating on / off
- Knobs for manual readjustment of the room temperature per heating circuit
- 3 buttons for manual operation and manual positioning commands

**Digital operating elements**

The entry or readjustment of all setting parameters, activation of optional functions and reading of actual values and statuses is made according to the operating line principle. An operating line with an associated number is assigned to each parameter, each actual value and each function that can be selected.

One pair of buttons is used to select an operating line and one pair to readjust the display.

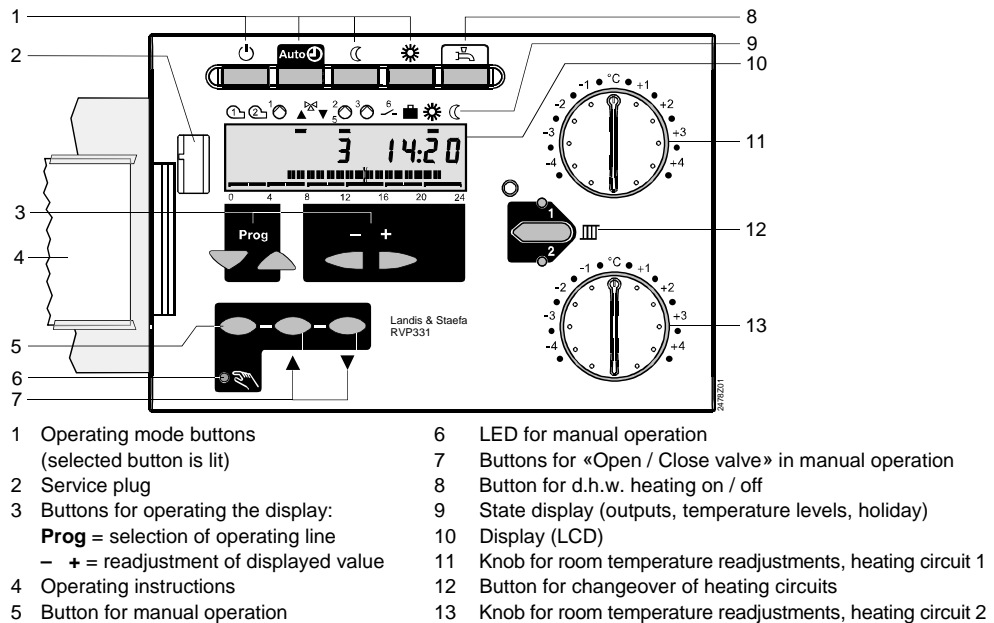

**Notes**

**Engineering**

- The wires of the measuring circuits carry extra low voltage
- The wires to the actuator and the pump carry AC 24...230 V.
- The local regulations for electrical installations must be complied with
- Sensor cables should not be run parallel to mains carrying cables for loads such as actuator, pump, burner, etc.

**Commissioning**

- On the room unit for heating circuit 2, the address to be set is 2
- Every controller is supplied complete with installation and commissioning instructions

## Technical data

General unit data	Operating voltage	AC 230 V +10/-15 %
	Frequency	50 Hz
	Power consumption	9 VA
	Perm. ambient temperature	
	Transport and storage	-25...+65 °C
	Operation	0...50 °C
	Backup of controller clock	min. 12 h
	Weight (net)	0.68 kg
Standards	Product safety	
	Automatic electrical controls for household and similar use	EN 60730-1
	Particular requirements for temperature sensing controls	EN 60730-2-9
	Degree of protection	IP 40 to EN 60529
	Safety class (if correctly installed)	II to EN 60730
	CE conformity to	
	EMC directive	89/336/EWG
	Low voltage directive	73/23/EWG
	EMC directive	
	Electromagnetic immunity	EN 50082-2
Electromagnetic emissions	EN 50081-1	
Output relays	Rated voltage	AC 230 V
	Rated current	2 (2) A
	Contact current at AC 24...90 V	0.1...2 A, $\cos \varphi > 0.6$
	Contact current at AC 90...250 V	0.02...2 A, $\cos \varphi > 0.6$
	Rated current of ignition transformer	1 A max. (30 s max.)
	Switch-on current of ignition transformer	10 A max. (10 ms max.)
	Max. switch-on current (fuse)	max. 10 A
Perm. cable lengths	To the sensors and external contacts	
	Copper cable 0.6 mm dia.	20 m
	Copper cable 1.0 mm <sup>2</sup>	80 m
	Copper cable 1.5 mm <sup>2</sup>	120 m
	To the room unit	
	Copper cable 0.25 mm <sup>2</sup>	25 m
Copper cable from 0.5 mm <sup>2</sup>	50 m	

## Connection diagrams

### Low voltage side

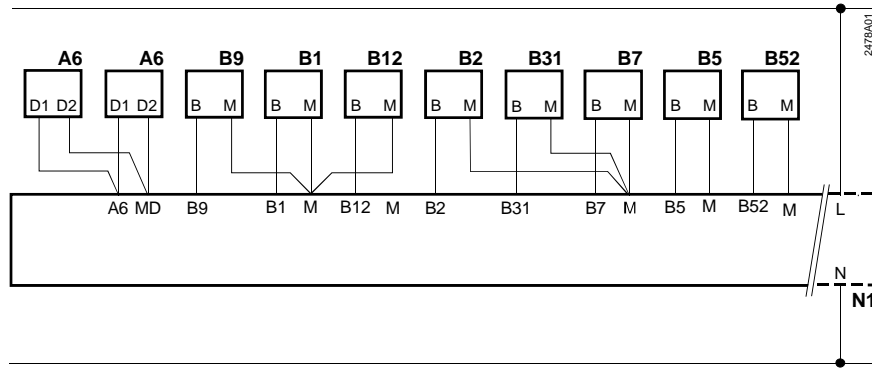

### Mains voltage side

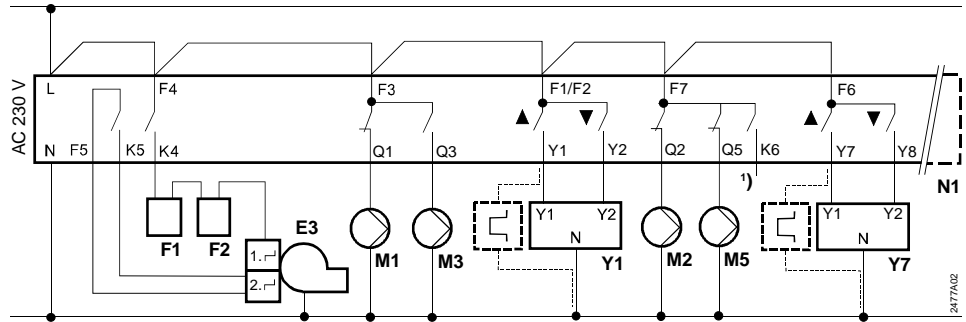

- |     |   |    |   |
|-----|---|----|---|
| A6  | Room units for heating circuits 1 and 2         | F1 | Limit thermostat                        |
| B1  | Flow sensor, heating circuit 1                  | F2 | Manual reset safety limit thermostat    |
| B12 | Flow sensor, heating circuit 2                  | M1 | Circulating pump                        |
| B2  | Boiler sensor                                   | M2 | Heating circuit pump, heating circuit 1 |
| B31 | D.h.w. storage tank sensor / control thermostat | M3 | Charging pump                           |
| B5  | Room sensor, heating circuit 1                  | M5 | Heating circuit pump, heating circuit 2 |
| B52 | Room sensor, heating circuit 2                  | N1 | Controller RVP331                       |
| B7  | Return sensor                                   | Y1 | Actuator heating circuit 1              |
| B9  | Outside sensor                                  | Y7 | Actuator heating circuit 2              |
| E3  | 2-stage burner                                  | 1) | Multi-functional output                 |

## Dimensions

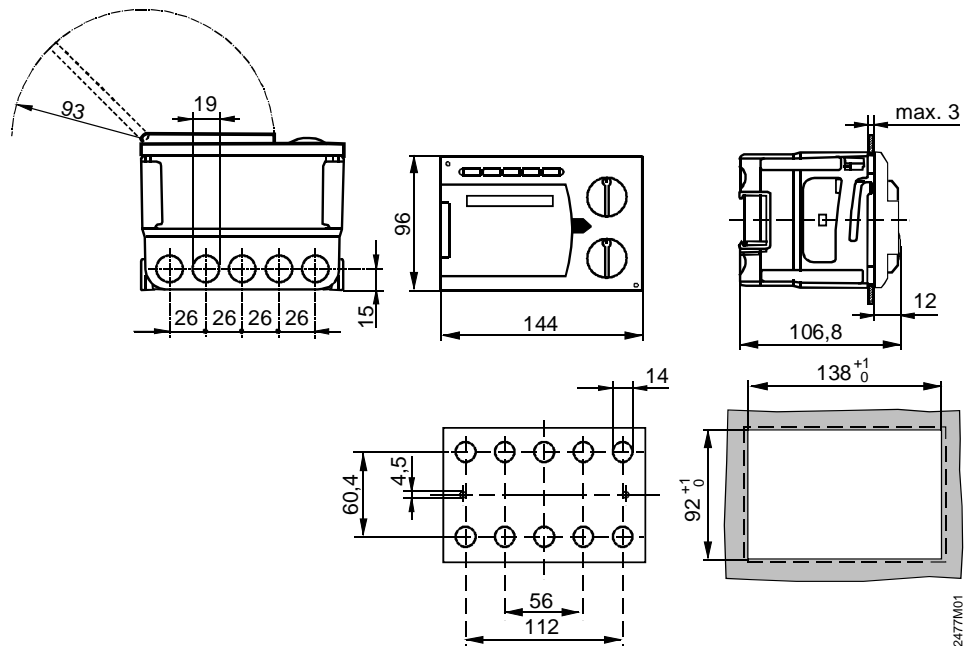

Dimensions in mm