

WIRING AND COMMISSIONING INFORMATION FOR SATCHWELL MICRONET MN550 CONTROLLERS

APPLICATION

Satchwell MicroNet MN550 Series Controllers are fully-programmable controllers designed for roof top, unit ventilator, air handling unit (AHU) and zone heating and cooling applications. These controllers feature built-in line voltage relays, universal inputs (UIs), digital (pulse counting) inputs (DIs), analogue outputs (AOs) and support for one MN-Sx digital sensor. The MN550 controller operates from an external 24Vac or 24Vdc supply.

By setting the controller's jumper pins, any of the universal inputs may be configured as an analogue, resistive, or dry (voltage free) contact input.

MN550 controllers can operate standalone or be networked in a MicroNet ARCNET® network or a Native Communications Protocol (NCP) network. For any model of controller, a PC with VisiSat™

Configuration Tool software (version 2.1 or later) is necessary to download and modify applications.

An optional Real-Time Clock card can be fitted, which maintains controller time during a power failure. The RTC card contains a 3V, 125mAh Lithium cell which has a life of at least 5 years.

Networked controllers receive time updates automatically from a MicroNet Manager Interface or Touch Screen time master.

A Satchwell MicroNet Touch Screen or LCD can be mounted onto the controller, which allows a user to view and modify controller properties. Please refer to the Touch Screen Engineering Data Sheet (DS 10.050A) or to the LCD Engineering Data Sheet (DS 10.060A).

The controller also features an onboard power capacitor, to preserve RAM for a maximum of seven days.

SPECIFICATION

Order Type	Description	Communications	Voltage	Inputs/Outputs
MN550-ARC	MicroNet 550 ARCNET Controller	ARCNET	24Vac 50/60Hz or 24Vdc	10 Universal inputs configurable for temperature, digital input or voltage (0 to 10Vdc) input. 6 DO line relays, 5.0A. 4 AOs providing 0 to 10Vdc at 1mA. Load resistance must be 10kΩ or more. 2 DIs - dry (voltage free) contact, pulse counting 10Hz maximum. 15Vdc (25mA) supply output for humidity and pressure sensors, etc.. 1 S-Link sensor.
MN550-NCP	MicroNet 550 NCP Controller	NCP		
MN550-XCOM	MicroNet 550 Dual NCP Controller	Dual NCP		



Data Sheets
DS 10.153 - MN550 Controllers
DS 10.202 - VisiSat Configuration Tool

Multi-Lingual Instructions
MLI 10.153 - Installation Instructions
MLI 10.310 - MN DK Installation Instructions



INSTALLATION

Inspection

Inspect carton for damage. If damaged, notify carrier immediately. Inspect controller for damage. Return damaged products.

Requirements

(These items are not provided)

- Installer must be an experienced technician.
- Job wiring diagrams.
- Tools:
 - Drill and bits for panel mounting screws.
 - Digital Volt- Ω meter (DVM).
 - Static protection wrist strap.
- EN 61558 power transformer as described opposite. Three No. 10 self-starting screws for wall mounting or 35mm DIN rail for mounting.

Precautions



**WARNINGS -
ELECTRICAL SHOCK HAZARD!
DISCONNECT POWER BEFORE INSTALLING OR
REMOVING THE COVER.**

General Cautions

Follow Static precautions when installing this equipment.

Use copper conductors that are suitable for 75°C.

Make all connections according to electrical wiring diagram.

Do not route relay output wiring with any other controller wiring.

Do not route triac output wiring with any other controller wiring.

Do not route power and output wiring with signal wiring.

Do not run Extra Low Voltage (24Vac or less) wiring in the same harness as mains wiring.

All installation wiring must conform to BS 6701:2004 and EN 50174.

Static Precautions

Static charges damage electronic components. The microprocessor and associated circuitry are extremely sensitive to static discharge. Use the following precautions when installing, servicing, or operating the system:

- Work in a static-free area.
- Discharge static electricity by touching a known, securely grounded object.
- Use a wrist strap connected to earth ground when handling the controller's printed circuit board.

European Community Directives

This equipment meets all requirements of European Community Directives for Low Voltage (72/23/EEC), General Safety (92/59/EEC), and Electromagnetic Compatibility (89/336/EEC).

Federal Communications Commission (FCC)

This equipment has been tested and found to comply with the limits for a Class A digital device, pursuant to Part 15 of the FCC Rules. These limits are designed to provide reasonable protection against harmful interference when the equipment is operated in a commercial environment. This equipment generates, uses, and can radiate radio frequency energy and, if not installed and used in accordance with the instruction manual, may cause harmful interference to radio communications. Operation of this equipment in a residential area is likely to cause harmful interference in which case the user will be required to correct the interference at his own expense.

Canadian Department of Communications (DOC)

This digital apparatus does not exceed the Class A limits for radio noise emissions from digital apparatus set out in the radio interference regulations of the Canadian Department of Communications.

Power Supply Wiring Precautions

- This product contains a non-isolated half-wave rectifier power supply and must not be powered by transformers used to power other devices containing non-isolated full-wave rectifier power supplies. Refer to DS 10.250, *EN-206, Guidelines for Powering Multiple Full-Wave and Half-Wave Rectifier Devices from a Common Transformer* for detailed information.
- The 24Vac 50/60Hz supply must comply with EN 61558 and be capable of supplying at least 12VA. Class 2 circuits must not intermix with Class 1 circuits. The supply to the transformer must have a breaker or disconnect.
- The transformer frame and controller GND terminal must be connected to earth; see page 7.

Mounting

Panel or DIN Rail Mounting

1. Select mounting location. Allow minimum 150mm clearance around controller.
2. Do the following to mount controller on a panel:
 - a. Loosen two screws securing terminal cover and remove cover.
 - b. If not already fitted, press the wall mounting clip into the back of the controller.
 - c. Lift wall mounting bracket clip. (Located on top back of controller.)
 - d. Using a No. 10 self-starting screw, install top screw.
 - e. Lift and level controller.
 - f. Using two No. 10 self-starting screws, install bottom screws.
 - g. Re-install terminal cover. (May be left off until wiring is completed.)
3. Do the following to mount controller on a DIN rail:
 - a. While pulling down on DIN rail locking bracket, snap controller base on a 35mm DIN mounting rail.
 - b. Release DIN rail locking bracket.

MOUNTING METHODS

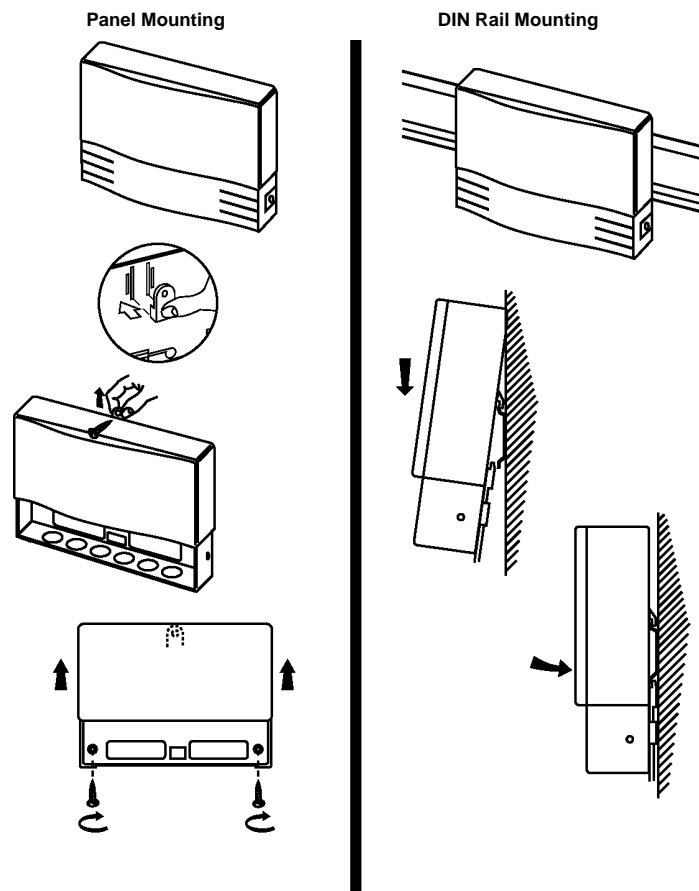

Location

The controllers are suitable for indoor use only. When selecting a mounting location, make certain the following conditions are met:

- Do not install where excessive moisture, corrosive fumes, vibration, or explosive vapours are present.
- Do not install near large contactors, electrical machinery, Variable Speed Drives (VSDs) or welding equipment.
- Allow 150mm clearance from contactors, switches, and associated cabling.

Locate where ambient temperatures do not exceed 50°C or fall below 0°C and relative humidity does not exceed 95% or fall below 5%, non-condensing.

Terminal Connections

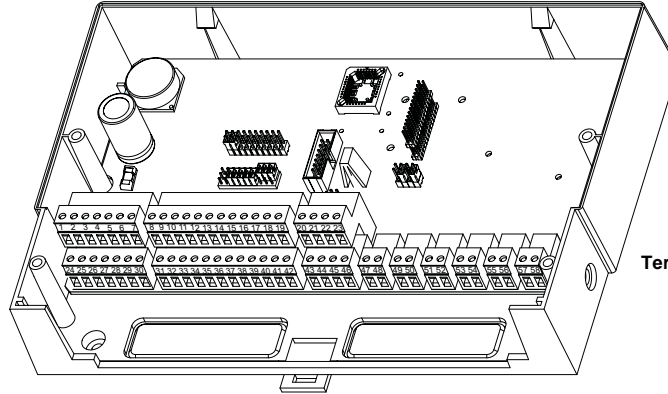

Terminals accept one 1.5mm² wire

WARNING - SEE WIRING PRECAUTIONS ON Page 2.

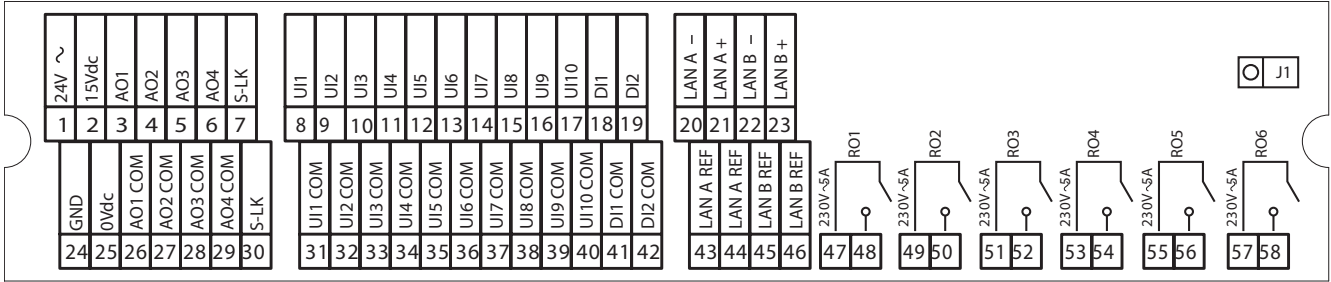

Wiring Routing Rules

The following table shows cable types that can be routed together:

	Comms ^a	S-Link	DI	UI	AO	DO 24Vac	DO 240Vac
Comms ^a	✓	✓	✓	✓	✓	✗	✗
S-Link	✓	✓	✓	✓	✓	✗	✗
DI	✓	✓	✓	✓ ^b	✓	✓ ^c	✗
UI	✓	✓	✓ ^b	✓	✓	✓ ^b	✗
AO	✓	✓	✓	✓	✓	✓ ^d	✗
DO 24Vac	✗	✗	✓ ^c	✓ ^b	✓ ^d	✓	✗
DO 240Vac	✗	✗	✗	✗	✗	✗	✓

- a Comms must always be screened.
- b Screen UI
- c Screen DI
- d Screen AO

Cable Screens

Earth each screen, but at only one end of the cable network, preferably at the GND terminal (14) of an MN50-MI-NCP/ARC. If earthing a screen at an MN550 controller, connect to terminal 24 (GND). Keep wires emerging from screened cable as short as possible (and not more than 150mm).

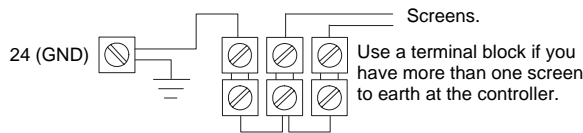

Note: Satisfactory NCP or ARCNET communications relies on the LAN REF potential varying no more than 12V between any two devices in the network (e.g. between an MN50-MI-NCP/ARC and any controller, or between any two controllers). If this is not the case, introduce NCP repeaters or ARCNET routers and connect the network as given in the *MicroNet System Engineering Guide*.

Network Wiring

Introduction

Network wiring includes a connection between the controller and a MicroNet controller network. Depending on the specific controller model, one of two network types can be used:

- NCP network
- ARCNET network

Note that termination of cable screens can be critical to performance, particularly in an ARCNET network. Network wire pairs must be dedicated to MicroNet network communications. They cannot be part of an active, bundled telephone trunk. If network cable is installed in areas of high RF/EMI, the cable must be in conduit.

Refer to the *MicroNet System Engineering Guide* for further guidance, including network topologies, wiring, network lengths, termination, screening and cable types.

NCP Network Wiring

MN550-NCP VARIANT

Controllers may be networked to either a 'main LAN' under an MN50-MI-NCP or to a 'sub-LAN' under a MicroNet Touch Screen.

Recommended cable for NCP networks is Belden 9502 dual twisted-pair screened cable for full opto-isolation in areas of high electrical noise. However, Belden 8762 (single twisted pair cable) can be used providing that the wiring precautions shown in the *MicroNet System Engineering Guide* are followed.

The terminals to use for network connections depend on whether or not a Touch Screen is mounted on the controller.

1. Review the Precautions section.
2. If applicable, fit or remove two links as shown in the following diagram:

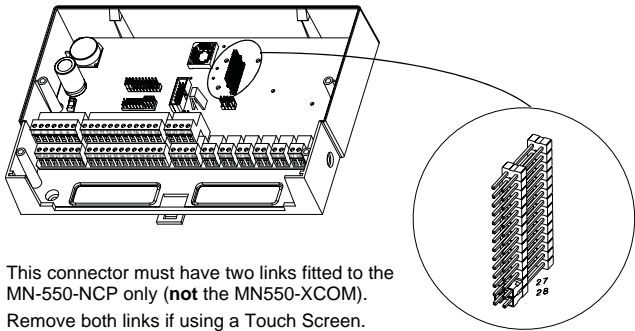

This connector must have two links fitted to the MN-550-NCP only (**not** the MN550-XCOM).
Remove both links if using a Touch Screen.

3. Connect the network to the controller, as shown in the following diagrams. **Observing correct polarity**, connect one pair of the dual twisted pair to the LAN and connect both wires of the other pair to one of the LAN isolated (LAN REF) reference terminal(s).
Note: Connect the controller with other NCP devices in a device-to-device fashion. Do not use wiring trees or stubs.

NCP Wiring when Touch Screen is not mounted on Controller:

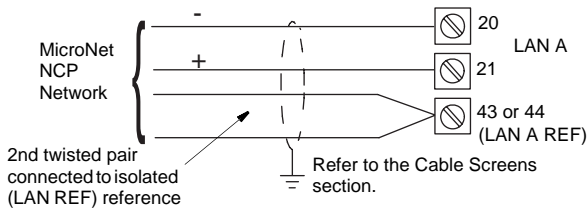

4. Ground the NCP wiring screen **at one end of the cable only**, e.g. at the earth terminal of an MN50-MI-NCP. Mounting a MicroNet Touch Screen in the controller causes the controller to be on a sub-LAN of the Touch Screen. If required, continue the MicroNet sub-LAN from pins 22, 23 and 45 or 46. The main LAN must connect to pins 20, 21 and 26 or 27.

NCP Wiring when Touch Screen is mounted on Controller:

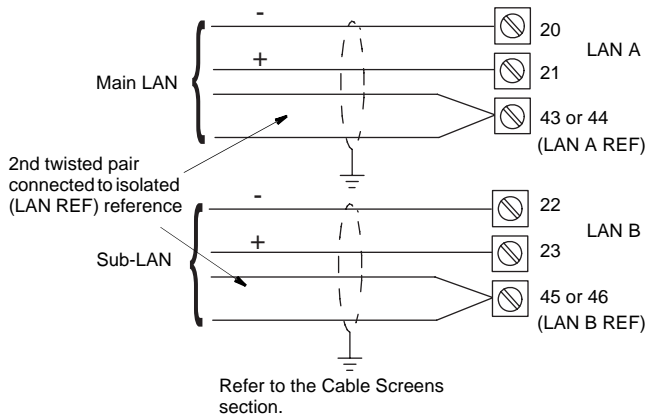

MN550-XCOM VARIANT

The MN-XCOM variant allows a local MN50-LCD to be connected to the LAN B at pins 22 and 23.

NCP Wiring when MN50-LCD is connected to the Controller (no ribbon cable connected):

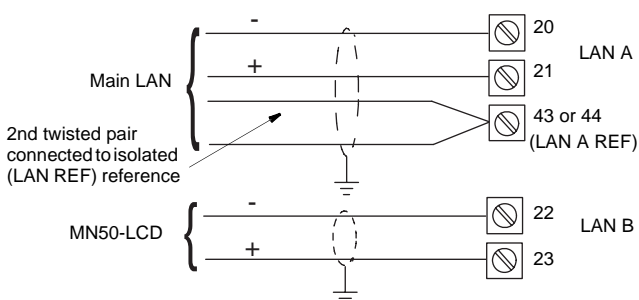

Ensure both links from daughter board header are removed.

Refer to the Cable Screens section.

ARCNET Network Wiring

Controllers may be networked to either a 'main LAN' under an MN50-MI-ARC or to a 'sub-LAN' under an ARCNET router (MN50-MI-RTR).

For performance reasons, when transferring network variables between controllers and Touch Screens, the main LAN should have only ARCNET routers connected to it, unless there are no sub-LANs. Recommended cable for ARCNET networks is Belden 9502 dual twisted-pair screened cable.

1. Review the Precautions section.
2. Ensure both links from the daughter board header are removed.
3. Connect the network to the controller, as shown in the following diagrams. **Observing correct polarity**, connect one pair of the dual twisted pair to the LAN and connect both wires of the other pair to one of the LAN isolated (LAN REF) reference terminal(s).
4. Connect the controller with other ARCNET devices in a device-to-device fashion. Do not use wiring trees or stubs.
5. Ground the ARCNET wiring screen **at one end of the cable only**, e.g. at the earth terminal of an MN50-MI-ARC.

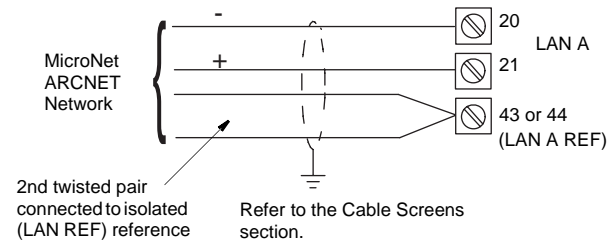

The devices *at each end* of the network must be biased and terminated by fitting jumpers to A, B and C of LK4. If the controller is not at one end, leave the links unset.

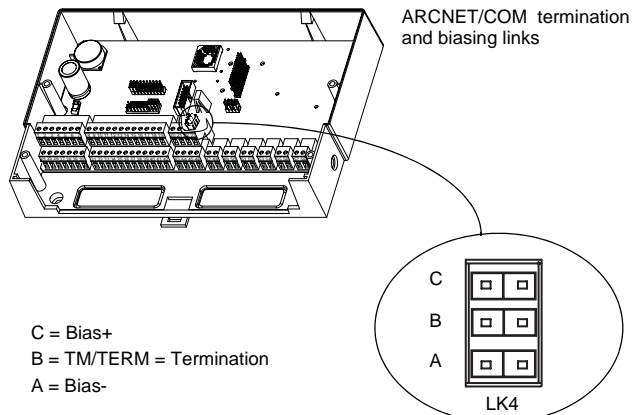

A local MN50-LCD can be connected to the controller at pins 22, 23 and 45 or 46:

NCP Wiring when MN50-LCD is connected to the Controller (no ribbon cable connected):

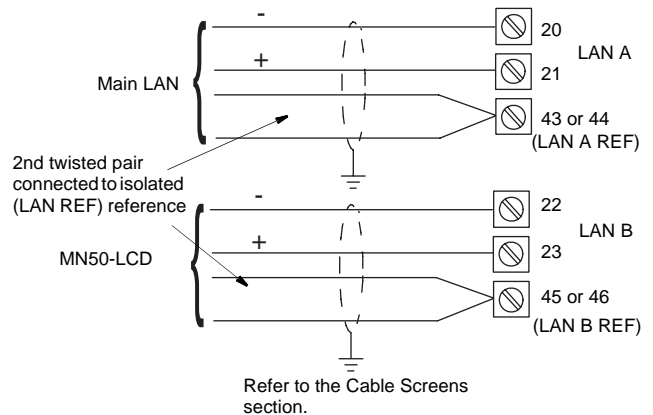

Refer to the Cable Screens section.

S-Link Sensor Wiring

1. Review the Precautions section.
2. Connect unscreened cable to terminals 7 and 30. Polarity makes no difference.

See the MN-Sx data sheet (DS 10.000A) for sensor connection details.



Universal Input (UI) Wiring

UI Configuration

Each UI must be configured as either a Voltage (0 to 10Vdc), Resistive/Temperature (0-10kΩ), or Digital Input. This must match the usage of the UI in the controller application. Configuration is achieved by placing the shorting block (jumper) onto the appropriate pins:

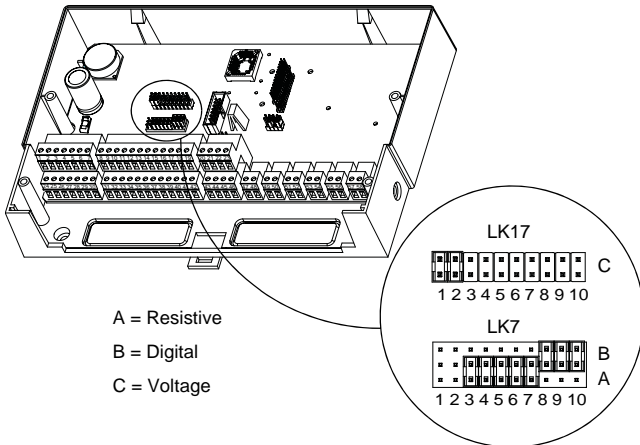

Refer to the controller's 'Controller Definition Drawing' in VisiSat for a picture of the required UI jumper settings for the controller. Factory default configuration is shown in the following table. If an input is not used, leave jumper in the default position.

Terminal Number	Input Number	Resistive A	Digital B	Voltage C
8	1			Link 1C
9	2			Link 2C
10	3	Link 3A		
11	4	Link 4A		
12	5	Link 5A		
13	6	Link 6A		
14	7	Link 7A		
15	8		Link 8B	
16	9		Link 9B	
17	10		Link 10B	

Note: Each device connected to a UI must use a separate signal and return conductor. If screened cable is used, connect the screen to ground at one end only.

Voltage UIs

Note: An externally powered 0 to 10Vdc sensor is required. The input impedance of a voltage input is 430kΩ.

1. Review the Precautions section.
2. Connect positive signal wire from 0 to 10Vdc device to desired input terminal (8, 9, 10, 11, 12, 13, 14, 15, 16, or 17).
3. Connect negative signal wire to one UI common (COM) terminal (31, 32, 33, 34, 35, 36, 37, 38, 39 or 40).

4. Make certain jumper is in Voltage position.

Configure input as Voltage UI

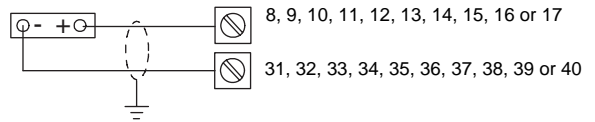

Refer to the Wiring Routing Rules section.

Resistive (Temperature) UIs

1. Review the Precautions section.
2. Connect one wire from the resistive device to desired input terminal (8, 9, 10, 11, 12, 13, 14, 15, 16 or 17). Polarity is not important.
3. Connect other wire to UI common (COM) terminal (31, 32, 33, 34, 35, 36, 37, 38, 39 or 40).
4. Make certain input configuration jumper is in Resistive position.

Configure input as Resistive UI:

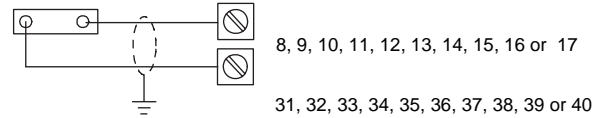

Refer to the Wiring Routing Rules section.

Digital UIs

Note: Only dry (voltage free) contacts can be monitored. Maximum count frequency is once every two seconds.

1. Review the Precautions section.
2. Connect one wire from field contact to desired input terminal (8, 9, 10, 11, 12, 13, 14, 15, 16 or 17). Polarity is not important.
3. Connect other wire to one UI common (COM) terminal (31, 32, 33, 34, 35, 36, 37, 38, 39 or 40).
4. Make certain input configuration jumper is in Digital position.

Configure input as Digital UI:

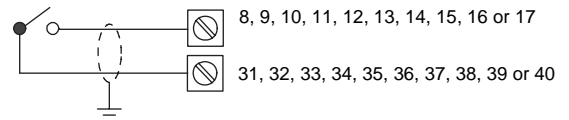

Refer to the Wiring Routing Rules section.

Wiring for 15Vdc Source

The 15Vdc terminal can provide a 25mA source for use with a DUSF sensor.

Connect load to terminal 2 and 25.

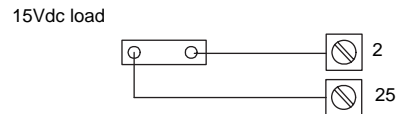

Digital Input (DI) Wiring

The two DIs (terminals 18 and 19) may be used for pulse rate monitoring or simple equipment (status) inputs. Only dry (voltage free) contacts can be monitored. Maximum input frequency is 10Hz.

Note: Although the digital (pulse) inputs are capable of monitoring inputs up to a speed of 10Hz, the actual speed depends on the application cycle time, i.e. how often the pulse input signal is passed to a counter module. Typically this is 2Hz or less.

1. Review the Precautions section.
2. Connect one wire from field contact to desired input terminal (18 or 19). Polarity is not important.
3. Connect other wire to the corresponding DI COM terminal (41 or 42).

The pulse count is active on the rising edge or the falling edge as set by Link 27. Select the rising or falling edge by placing the jumpers across the appropriate terminal:

Note: These jumpers must not be removed completely.

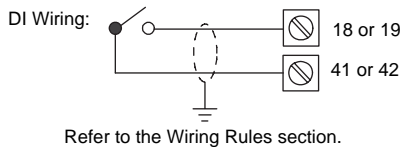
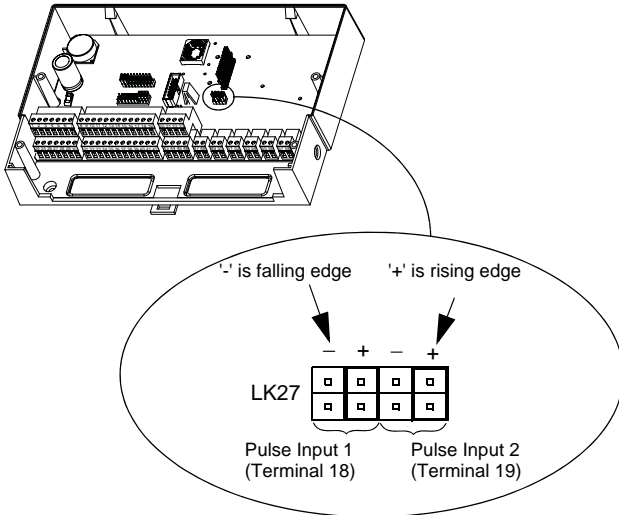

Relay Output Wiring

The Relay Outputs are normally open voltage-free line relays for switching 230Vac, 5A loads. Each load must be externally powered.



**WARNINGS -
ELECTRICAL SHOCK HAZARD!
DISCONNECT POWER BEFORE INSTALLING OR
REMOVING THE COVER.**

Note: The selected wire gauge must be consistent with load current rating.

1. Review the Precautions section.
2. Connect one wire from load to be switched to desired input terminal (47, 49, 51, 53, 55 or 57).
3. Connect other side of load to output terminal (48, 50, 52, 54, 56 or 58).

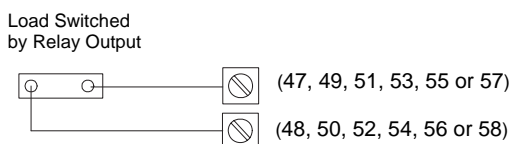

Analogue Output (AO) Wiring

AO1 to AO4 supply from 0 to 10Vdc to modulate a voltage controlled device.

- Minimum input impedance for a device or actuator operated by an AO is 10kΩ.
 - The maximum current that a 0-10Vdc output can source is 1mA.
4. Review the Precautions section. Connect positive signal wire to desired output terminal (3, 4, 5 or 6).

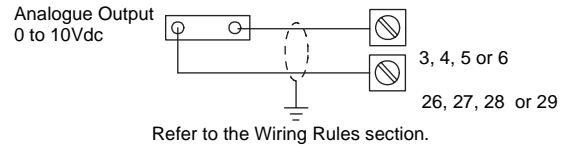

Connect negative signal wire to the corresponding AO COM terminal 26, 27, 28 or 29).

Power Supply Wiring

Notes:

1. If using a touch screen via the ribbon cable, MN550 must be supplied from 24Vac, not 24Vdc.
2. This product contains a non-isolated half-wave rectifier power supply and must not be powered by transformers used to power other devices containing non-isolated full-wave rectifier power supplies. If multiple devices are powered from the same transformer, verify that the transformer is properly sized to power all equipment simultaneously and all devices contain the same type of rectifier power supplies or internal isolation. Also verify that correct polarity has been maintained between all connected devices. Refer to DS 10.250, EN-206, Guidelines for Powering Multiple Full-Wave and Half-Wave Rectifier Devices from a Common Transformer for detailed information.
3. Install wiring according to job wiring diagrams and local electrical codes.

The wire gauge used must be consistent with load current rating.

24Vac Power Wiring

1. Review the Precautions section.
2. Ensure that the controller GND terminal is connected to Earth **before** connecting the power wiring to the controller.
3. Connect power ground wiring to terminal 24 (GND).
4. Connect power 24Vac wiring to terminal 1 (24V~).

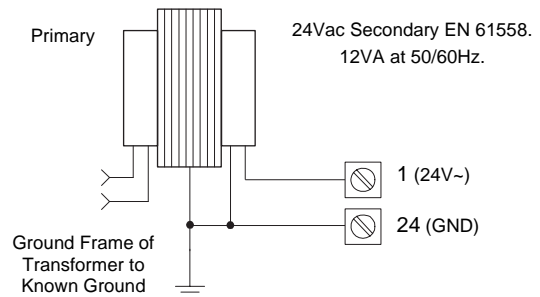

24Vdc Power Wiring

1. Review the Precautions section.
2. Ensure that the controller GND terminal is connected to Earth **before** connecting the power wiring to the controller.
3. Connect power ground wiring to terminal 24 (GND).
4. Connect power 24Vdc to terminal 1 (24V~).

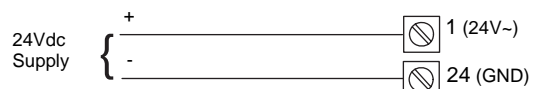

CHECKOUT

Electrical Checkout

1. If controller is part of a MicroNet NCP or ARCNET network, verify network wiring between controller and other devices is installed according to job wiring diagram and national and local electrical codes.
2. If operated from a 24V supply, verify that 24Vac power is provided from a power transformer conforming to EN 61558 and wiring is installed according to job wiring diagrams and with national and local electrical codes.
3. Verify input jumpers are in correct position.
4. Verify outputs are wired according to job wiring diagram and with national and local electrical codes.
5. Make certain current requirements of the controlled device do not exceed rating of controller's digital outputs.

Setting the Address of an NCP/ARCNET Controller

Each controller or other device on the same NCP or ARCNET LAN needs a unique node address. The node address of two controllers can be the same if they are on different LANs; that is, separated by a Touch Screen (NCP networks) or router (ARCNET networks).

Set the node address using switches 1 to 7 in bit switch S1. Do this before powering up and cold starting the controller.

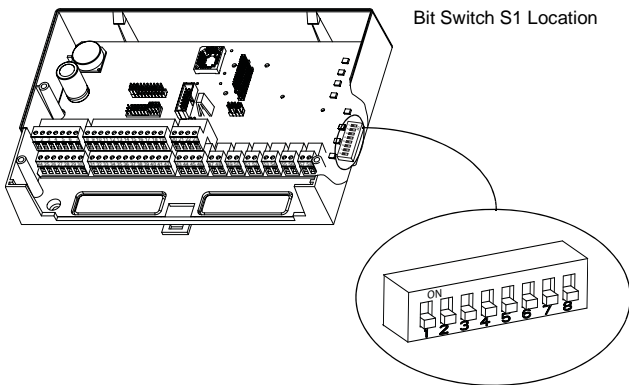

NCP/ARCNET CONTROLLER ADDRESS

Switch Number	OFF Position	ON Position
1	0	1
2	0	2
3	0	4
4	0	8
5	0	16
6	0	32
7	0	64

Example: Placing switches 1, 3 and 6 in the ON position and switches 2, 4, 5 and 7 in the OFF position sets controller address to 37:

Switch Number	OFF Position	ON Position
1	ON	1
2	OFF	0
3	ON	4
4	OFF	0
5	OFF	0
6	ON	32
7	OFF	0
TOTAL		Node Address = 37

Although the controller's address is set using the switches, the controller's address is activated only after the controller is cold or warm started, as described on page 8. If the address has not been activated, you will not be able to connect to the controller from VisiSat.

Cold and Warm Starting the Controller

Cold Start

Caution: If the controller's Configuration Locked property has not been set to Yes in VisiSat, the cold start procedure clears all configuration data from the non-volatile EEPROM of the controller. This means the control application will be erased.

A cold start is normally performed only once when controller is first installed and before the controller application is downloaded. A cold start results in all controller outputs OFF until an application is downloaded. The cold start is performed using the controller's switch S1.

To perform a cold start:

1. Verify all devices connected to controller are in a manually controlled safe state.
2. Energize controller and verify the following:
 - Green 'Heartbeat' LED (LD5) is steady on for a short period.
 - After steady on period, the green LED adopts a normal 'heartbeat' flash rate.
3. Place bit switch 8 in ON position and then return to OFF position. (green LED will flash rapidly for several seconds and then return to normal 'heartbeat' rate.)

Notes:

1. Refer to 'Diagnostics LEDs' section if required.
2. An online controller can also be cold started from VisiSat using **Force Defaults** in the controller's System object in Bubbleland.

Warm Start

A warm start resets the controller and causes any change of address to be activated. When the controller is warm started, all EEPROM-resident values are retained. However, controller outputs cannot be guaranteed to stay at their present state.

To perform a warm start:

1. Verify all devices connected to controller are in a manually controlled safe state.
2. Do one of the following:
 - Select the **Force Reset** option from the controller's System object in Bubbleland (the controller must be online).
 - Cold start the controller with the controller's **Configuration Locked** property set to Yes.
 - Switch the power to the device Off, then On again.

Diagnostic LEDs

Location of LEDs (if fitted)

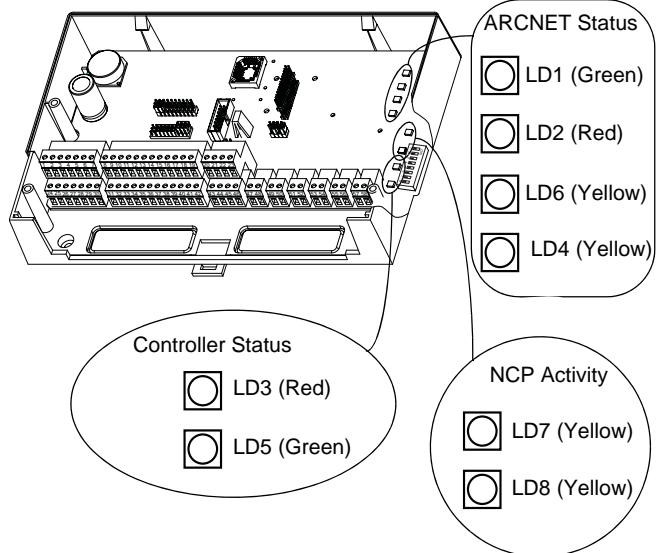

CONTROLLER STATUS LEDs

The Controller Status LEDs LD3 and LD5 have the following meanings:

LD3 (Red, 'Error' LED)	<p>Indicates that the unit has a problem requiring attention as follows:</p> <ul style="list-style-type: none"> • Long pulse at Flasher object rate (see note) - Node Error. • 50% pulse at Flasher object rate (see note) - Null Outputs. • Short pulse at Flasher object rate (see note) - Unprogrammed. • Very fast strobe - Uncalibrated. <p>Note: The pulse rate is determined by the Flash rate set up in the System Flasher object in bubbleland (default 1 flash per second).</p>
LD5 (Green 'Heartbeat' LED)	<p>ARCNET only:</p> <ul style="list-style-type: none"> • Pulsing (more on than off) - indicates a duplicate ARCNET node ID • Pulsing (more off than on) - indicates that ARCNET is initialising and seeking other nodes. <p>NCP/ARCNET:</p> <ul style="list-style-type: none"> • Flashing on and off at Flasher object rate (see note) - indicates unit is running correctly. • Fast strobing - indicates that the unit is initialising and reading/writing to EEPROM.

NCP LEDs

LEDs LD7 and LD8 have the following meanings:

LD7 (Yellow 'Rx' LED)	Indicates successful reception of NCP data packets.
LD8 (Yellow 'Tx' LED)	Indicates successful transmission of NCP data packets.

ARCNET LEDs

LEDs LD1 and LD2 have the following meanings:

LD1 (Green, 'Online' LED)	<ul style="list-style-type: none"> • Constantly on - indicates that the ARCNET node is on line and connected to the network (normal use). • Flashing on and off - indicates network connection has been lost and reconnection is being established.
LD2 (Red, 'Error' LED)	<ul style="list-style-type: none"> • Off - indicates normal operating condition. Flashes at start up. • Long on and off periods - indicates network connection failure • Short on and off periods - indicates recent node network connection or disconnection (possible network problem if occurring frequently). • Constantly on - indicates a bus wiring fault. • Flashing - indicates that the node is not connected to the network (floating node)
LD4 (Yellow 'Rx' LED)	Indicates successful reception of ARCNET data packets.
LD6 (Yellow 'Tx' LED)	Indicates successful transmission of ARCNET data packets.

SERVICING

Components within the controllers cannot be field repaired. If there is a problem with a controller, carry out the following procedure before contacting your local sales office.

1. Make sure controllers are connected and communicating to desired devices.
2. Check all sensors and controlled devices are properly connected and responding correctly.
3. If controller is operating, make sure the correct application is loaded by using the VisiSat Configuration Tool. For more information, see the *VisiSat Engineering Guide*.
4. Cold start the device and reload its application.
5. Record precise hardware setup, indicating the following:
 - Controller firmware version number.
 - Information regarding the Version number and build number of the VisiSat Configuration Tool (see 'About VisiSat' option in the VisiSat Tool Help menu).
 - A complete description of difficulties encountered.
 - A description of the status of the diagnostic LEDs.

Fuse Replacement



WARNING - ELECTRICAL SHOCK HAZARD!
REMOVE ALL POWER FROM THE CONTROLLER BEFORE CHANGING THE FUSE.

A fuse provides overcurrent protection for the controller. Observing static precautions, do the following to check and replace fuse.

1. Turn OFF all power to controller.
2. Remove controller covers.
3. Remove fuse using long nose pliers or similar.
4. Check continuity across fuse.
5. If fuse is faulty, replace fuse with same type and rating (1A anti-surge).
6. Re-install cover. Turn ON power to controller.

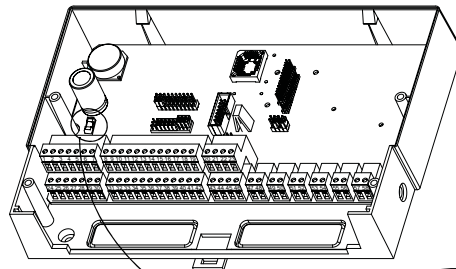

Remove and replace fuse using long nose pliers or tweezers

Fuse holder

Fuse

DIMENSION DRAWING

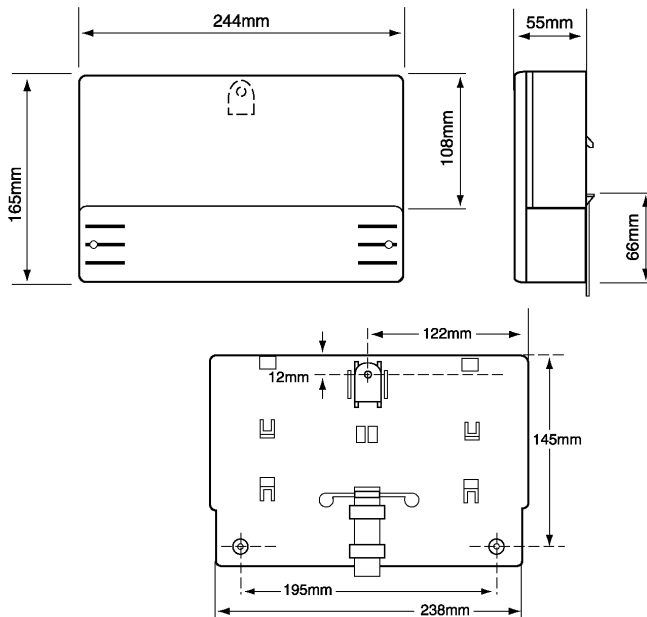

Weights:
 MN550 approx. 900g
 RTC Card approx. 6g

WARNINGS -

ELECTRICAL SHOCK HAZARD. REMOVE ALL POWER FROM BOTH THE CONTROLLER AND RELAY OUTPUTS BEFORE MAKING TERMINATIONS OR CHANGING CONFIGURATION INPUT JUMPERS.

Cautions

- Wiring Precautions shown on Page 2 must be observed.
- Do not apply any voltages until a qualified technician has checked the system and the commissioning procedures have been completed.
- This is a 24Vac/dc device. Do not exceed rated voltage. Local wiring regulations and usual safety precautions apply.
- 24Vac must be supplied by a transformer conforming to EN 61558.
- If any equipment covers have to be removed during the installation of this equipment, ensure that they are refitted after installation to comply with UL and CE safety requirements.
- Do not exceed the maximum ambient temperature.
- Interference with parts under sealed covers invalidates guarantee.
- Do not charge, short-circuit or solder the MN RTC battery. Do not allow contact with water, nor heat, disassemble or dispose of in fire. Do not reverse polarity in application.
- The design and performance of TAC Satchwell equipment is subject to improvement and therefore liable to alteration without notice.
- Information is given for guidance only and TAC Satchwell does not accept responsibility for the selection or installation of its products unless information is given by the Company in writing relating to a specific application.
- All installation wiring must conform to BS 6701:2004 and EN 50174.
- A periodic system and tuning check of the control system is recommended. Please contact your local sales office for details.

Copyright © 2006, TAC AB
 All brand names, trademarks and registered trademarks are the property of their respective owners. Information contained within this document is subject to change without notice. All rights reserved.

DS 10.153A 05/06



TAC Headquarters
 Malmö, Sweden
 +46 40 38 68 50

Satchwell Helpline
 +44 (0) 1753 611000
 satchwell.info@uk.tac.com

www.tac.com

