

M700 is a spring return electro-mechanical actuator for the control of two-way and three-way plug valves in:

- domestic hot water systems
- heating systems
- air handling systems

M700 is either controlled by an increase/decrease signal or by a modulating 2–10 V control signal. Modulating control makes for a faster positioning of the actuator.

The electronic circuitry of the actuator ensures that the running time is the same, regardless of the stroke of the valve in question.

It is easy to mount and connect the actuator. It can be mounted directly onto TAC's control valves, without any mounting kit.

For Satchwell valves a linkage is included (see PART NUMBERS on page 2).

The working range of the actuator is adjusted automatically depending on the stroke of the valve. The electronic circuitry of the actuator then takes care of the adjustment of the valve end positions.

The actuator is supplied by 24 V AC. It can provide 16 V DC voltage supply for older TAC controllers.

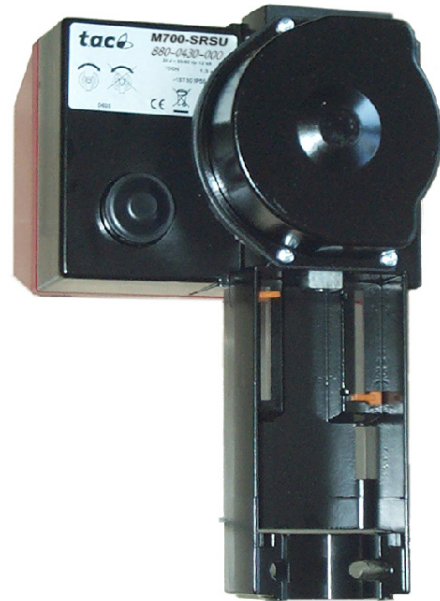

TUV
APPROVED

TECHNICAL DATA, M700

Part numbers	see the table on the next page
Supply voltage	24 V AC +25%/ -30%, 50–60 Hz
Power consumption	average 30 VA
Transformer sizing	50 VA
Running time:	
Modulating 10-25 mm (0.39 - 1 in.)	15 s
Modulating 25-32 mm (1 - 1.26 in.)	20 s
Modulating 10-52 mm (0.39 - 2.05 in.)	30 s
Increase/decrease	300 s/60 s
Spring return close off time at power failure:	
Less than 35 seconds	20 mm (0.78 in.)
Less than 65 seconds	45 mm (1.77 in.)
Stroke	9–52 mm (0.35 - 2.04 in.)
Factory set stroke	20 mm (0.78 in.)
Thrust	700 N (180 lbf.)
Duty cycle	max. 20%/60 minutes
Analog input:	
Voltage	0–10 V
Impedance	min 100 kΩ
Digital inputs VH–VC:	
Voltage across open input	24 V AC
Current through closed input	5 mA
Pulse time	min. 20 ms
Output G1:	
Voltage	16 V DC ±0.3 V
Load	25 mA, short-circuit proof

Output Y:	
Voltage	2-10 V (0-100%)
Load	2 mA
Ambient temperature:	
Operation	–10 – +50 °C (14°F - 122°F)
Storage	–10 – +50 °C (14°F - 122°F)
Ambient humidity	max. 90% RH
Enclosure rating	IP 54
Sound power level	max. 50 dBA
Standards:	
Emission	EN 50081-1:1992
Immunity	EN 50082-1:1992
Heat	IEC-68-2-2
Humidity	IEC-68-2-3
Cold	IEC-68-2-1
Vibration	IEC-68-2-6
Material:	
Housing	aluminium
Cover	ABS plastic
Color	black/red
Weight	1.8 kg (3.96 lb.)
Dimensions (mm)	refer to the table on the next page
Third Party approval	TUV

PART NUMBERS

Designation	Explanation	Part number
M700-SRSU	modulating control signal or increase/decrease signal, "Stem Up" spring action (the stem is pulled up when power off)	880-0430-000
M700-S2-SRSU	modulating control signal or increase/decrease signal, "Stem Up" spring action (the stem is pulled up when power off) and end point switches	880-0431-000
M700-SRSD	modulating control signal or increase/decrease signal, "Stem Down" spring action (the stem is pushed down when power off)	880-0440-000
M700-S2-SRSD	modulating control signal or increase/decrease signal, "Stem Down" spring action (the stem is pushed down when power off) and end point switches	880-0441-000
M700-SRSU+L7SV	modulating control signal or increase/decrease signal, "Stem Up" spring action (the stem is pulled up when power off), including a linkage for Satchwell valves	880-0630-000
M700-S2-SRSU+L7SV	modulating control signal or increase/decrease signal, "Stem Up" spring action (the stem is pulled up when power off) and end point switches, including a linkage for Satchwell valves	880-0631-000
M700-SRSD+L7SV	modulating control signal or increase/decrease signal, "Stem Down" spring action (the stem is pushed down when power off), including a linkage for Satchwell valves	880-0640-000
M700-S2-SRSD+L7SV	modulating control signal or increase/decrease signal, "Stem Down" spring action (the stem is pushed down when power off) and end point switches, including a linkage for Satchwell valves	880-0641-000

DIMENSIONS

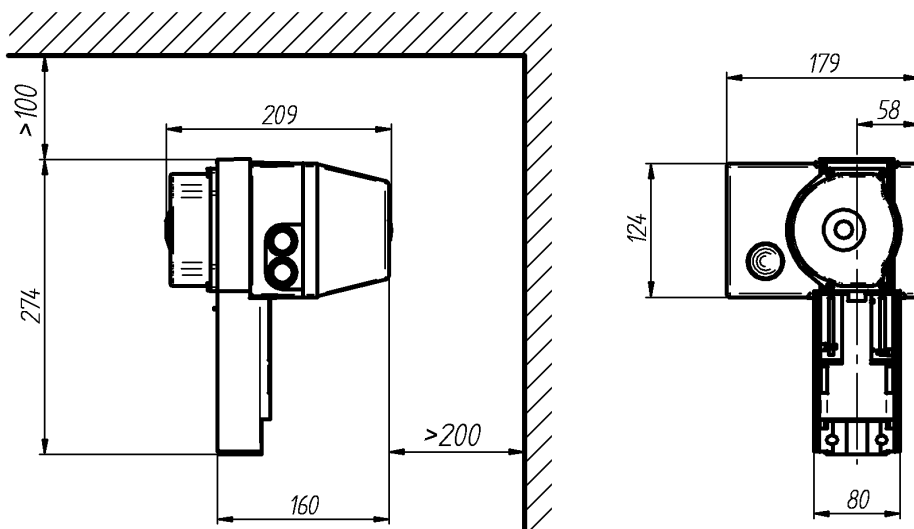

Figure 1

FUNCTION

The actuator

The brushless DC-motor of the actuator turns a screw via a gear wheel. The motor receives a control signal from a controller. The screw gets a linear movement which moves the stem of the valve.

In case of power loss, the spring will bring the actuator totally up ("SRSU" models) or totally down ("SRSD" models)

Control signal

M700 can either be controlled by an increase/decrease signal or by a variable direct voltage.

If an increase/decrease signal is used, the actuator normally moves inwards on an increase signal and outwards on a decrease signal, see Settings.

Manual operation

Due to the safety function implemented, manually operating the actuator is only possible when power off using a 10 mm wrench (see figure 2).

Position feedback

Forta actuators are equipped with a 2–10 V DC position feedback signal, where 2 V always corresponds to the closed position and 10 V to the open position.

End point switches

When actuators are controlled in sequence, it is possible to use the end point switches that have set positions. They will toggle when the valve is fully open or fully closed, respectively.

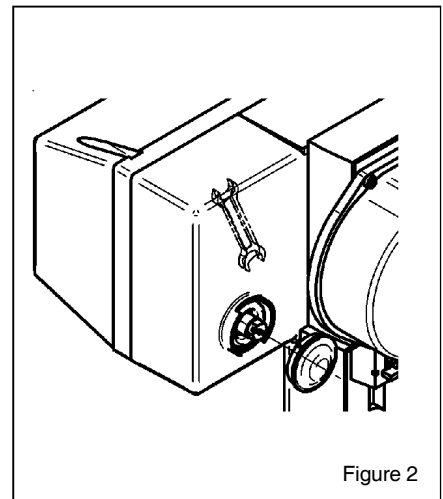

Figure 2

MOUNTING

The actuator may be mounted horizontally, vertically and in any position in between, but **not** upside down, see figure 3.

N.B.! Do not use the actuator for the DN15 valves V298, V282, V294, V384, V386 and V394.

To mount the actuator on a valve, slide the actuator onto the valve neck, thus making the square nut on the valve spindle fit into the groove on the cross bar. Then slide the brace into the groove on the valve neck and secure the nuts.

N.B.! When coupling the spindle, register it to get a small spring pre-load.

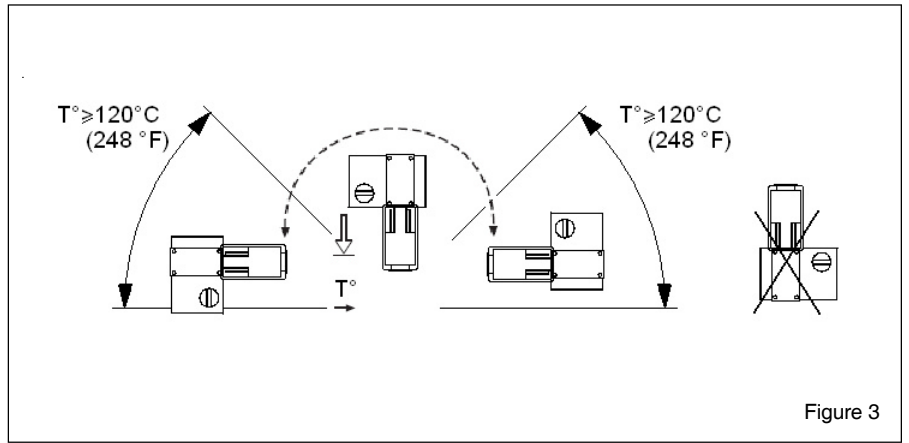

Figure 3

CONNECTIONS

Block	Function	Description
G	24 V AC	Supply voltage
G0	24 V AC rtm	
X1	Input	Control signals (VH, VC short-circuited to G0)
MX	Input, neutral	
VH	Increase	Supply for RC
VC	Decrease	
G1	16 V DC	Feedback signal
Y	0–100 %	

N.B.! When installed with three conductors, where the control signal reference is connected to G0, the motor current of the actuator will cause varying voltage loss in the cable and thus in the reference level. Forta, which has a highly sensitive control signal input, will detect the varying signal and follow it, which makes it difficult for the actuator to find a stable position.

This variation may be accepted in simplified installations on the following conditions: the cables between the controller and actuator are shorter than 100 m (328 ft.), the cross-sectional area

is larger than 1.5 mm² (AWG 16) and the cables are only connected to *one* actuator. Please refer to the figures labelled “Simplified installation” for wiring instructions.

Cable lengths

The cables to G, G0 and G1 should be max. 100 m (328 ft.) and have a cross-sectional area of min. 1.5 mm² (AWG 16).

Other cables should be max. 200 m (656 ft.) and have a cross-sectional area of min. 0.5 mm² (AWG 20).

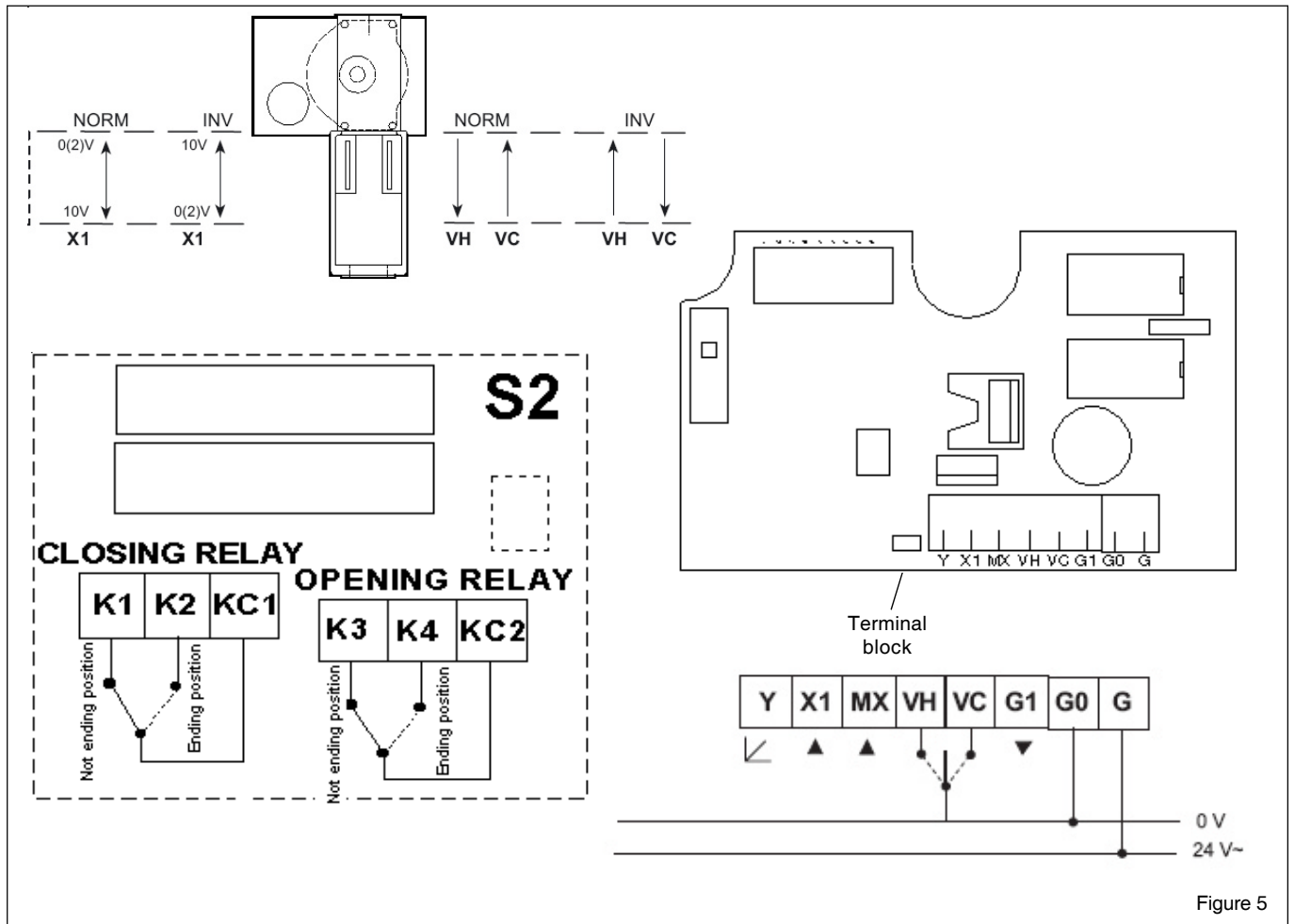
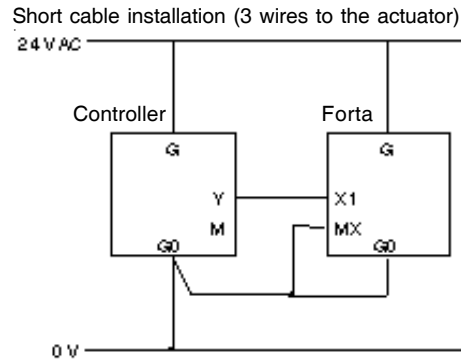
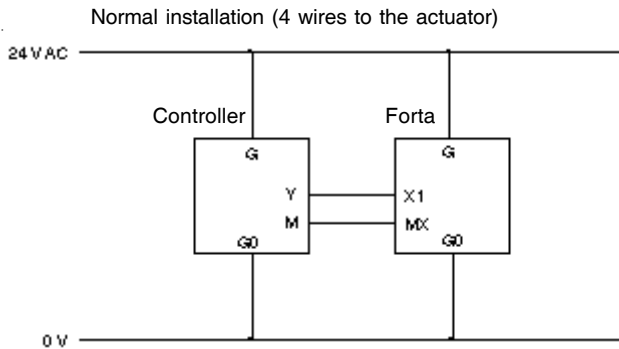
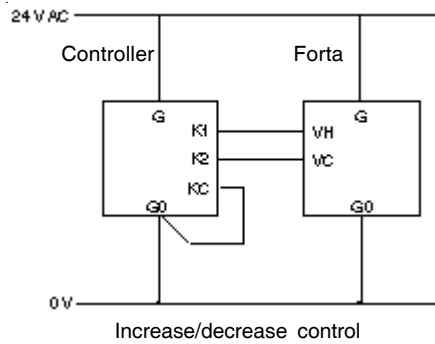
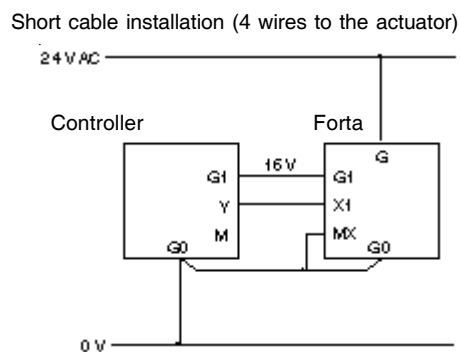
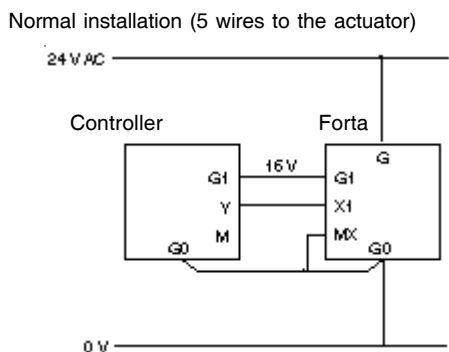

Figure 5



Modulating control, 24 V AC supply to the controller
(TAC 239W, TAC 6711, TAC Xenta, TAC 8000, TAC 230U, TAC 2000, TAC 9000, TAC 77xx)



Modulating control, 16 V DC supply to the controller
(TAC 218E/RM, TAC 221L, TAC 228R/RL/RF, TAC 239W, TAC 258R/RL, TAC 268R/RL/RF)

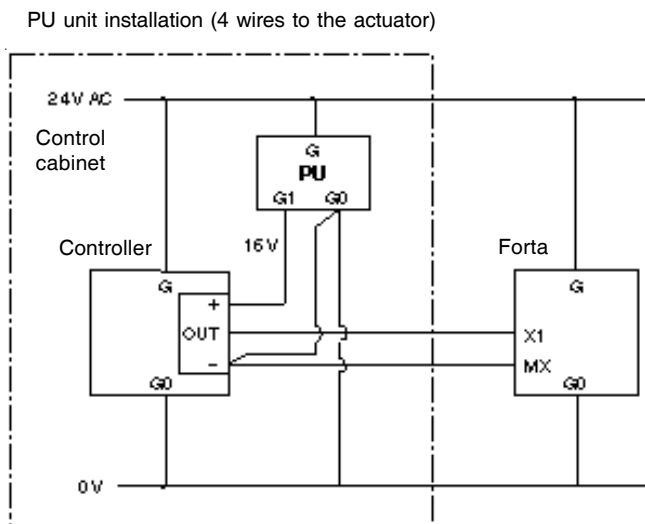
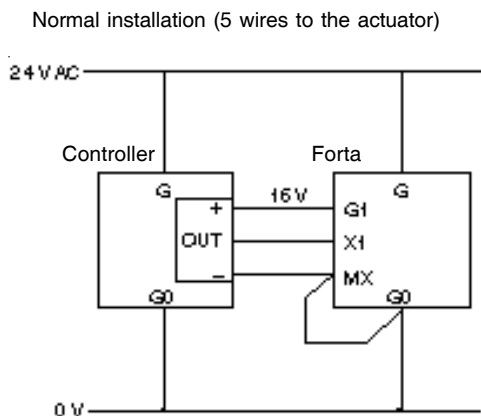

Modulating control, galvanically isolated output in the controller (TAC 6501, TAC 6505)

Figure 6

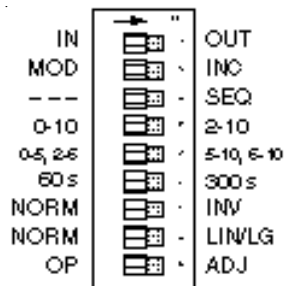

Function in the "OFF" pos.	"ON" position	Description
1 In	Out	Valve closing screw direction
2 Modulating	Increase/decrease	Control (not at Sequence)
3 -	Sequence	Sequence control
4 0-10 V	2-10 V	Voltage range
5 0-5 V, 2-6 V	5-10 V, 6-10 V	Part of voltage range
6 60 s	300 s	Running time
7 Normal	Inverted	Direction of movement
8 Normal	Linear/Logarithmic	Valve characteristic
9 Operation	End position adjust (mom.)	Operation/End position adjustment

Figure 8

There are nine switches in a row on the circuit board. On delivery ('Factory'), all switches are in the "OFF" position.

1 Valve Closing Screw Direction—IN / OUT

IN direction of movement is used when the screw of the actuator moves inwards to close the valve.

OUT direction of movement is used when the screw of the actuator moves outwards to close the valve.

2 Control signal—MOD / INC

TAC Forta can either be controlled by a variable direct voltage, a so called modulating signal (MOD), or by an increase/decrease signal (INC).

3 Sequence or parallel control—--- / SEQ

With sequence (or parallel) control (SEQ), two actuators/valves can be controlled by only one control signal.

For each of these you can choose which part of the voltage range to use, the upper one, 5-10 V (6-10 V) or the lower one, 0-5 V (2-6 V).

If the switch NORM / INV is in the NORM position, the higher voltage corresponds to 100% flow and the lower one to 0%.

With NORM / INV in the INV position you will get the opposite function.

Note! If sequence or parallel control is **not** used, the switch --- / SEQ must be in the OFF position, as the switch MOD / INC is not valid during sequence or parallel control.

4 Voltage range—0-10 / 2-10

You can choose whether to use the control signal voltage range 0-10 V or 2-10 V.

5 Part of voltage range—0-5, 2-6 / 5-10, 6-10

You can choose which part of a voltage range to use, the lower one 0-5 V (2-6 V) or the upper one 5-10 V (6-10 V).

If the switch is in the NORM position, the higher voltage corresponds to 100% flow and the lower one to 0%. To achieve the opposite function, the switch should be put in its INV position.

6 Running time—60 s / 300 s

With increase/decrease control, you can choose a running time between 60 s or 300 s.

With modulating control, the running time is always 15 s / 20 s / 30 s.

7 Direction of movement—NORM / INV

When normal direction of movement is used, the screw of the actuator moves inwards when the control voltage decreases or if the actuator gets a decrease signal.

With the switch NORM / INV, the direction of movement can be changed.

8 Linearization—NORM / LIN/LG

The motorized valve characteristics can be modified. If you wish for the characteristics to be affected, the setting LIN/LG will make the characteristics of an equally modified percentage (EQM) valve almost linear.

On the other hand, with LIN/LG a motorized valve equipped with a linear valve will operate with "Quick open characteristics". This means that with a small control signal, the valve will be almost completely open.

Note! For the actuator to register new settings of the switches, the supply voltage must be cut, the settings done, and then the power on

or

the end position adjustment must be done again (see point 9).

(This does not apply to the switch OP/ADJ).

9 End position adjustment—OP / ADJ

This switch is only used to adjust the end positions when the actuator is commissioned.

Momentarily put the switch in the ON position. The actuator will automatically find the end positions of the valve.

At the end of the adjustment all the other dip switch settings (1 to 8) will be read again.

ACTUATOR INSTALLATION

The switches on the circuit board should be set before the actuator is installed. There are no other switches or potentiometers that should be set or adjusted.

To make an end position adjustment, you only have to switch the switch »OP/ADJ« into its ADJ position, when the supply voltage has been turned on, and then back to its OP position.

When an end position adjustment is made, Forta closes the valve and opens it fully. The adjustment is finished by the actuator closing the valve again; the electronic circuitry then adjusts the stroke and the running time to the valve. The set values are stored in the EEPROM of the actuator so that they will remain after a loss of voltage.

When the end position adjustment is complete, the actuator starts to control the valve according to the control signal.



Hot media hazard. Before removing actuator from valve or opening the valve, ensure that the valve control medium is isolated and relieve the pressure. Work should only be carried out by a competent engineer.

MAINTENANCE

The actuator is maintenance-free.

ACCESSORIES

S2-Forta	880-0104-000
Circuit board M700-SRSU	1-001-0678-0
Circuit board M700-SRSD	1-001-0679-0
Linkage Satchwell valves L7SV	880-0126-000
See data sheet "Valves and actuators Summary" (F-10-06)	