

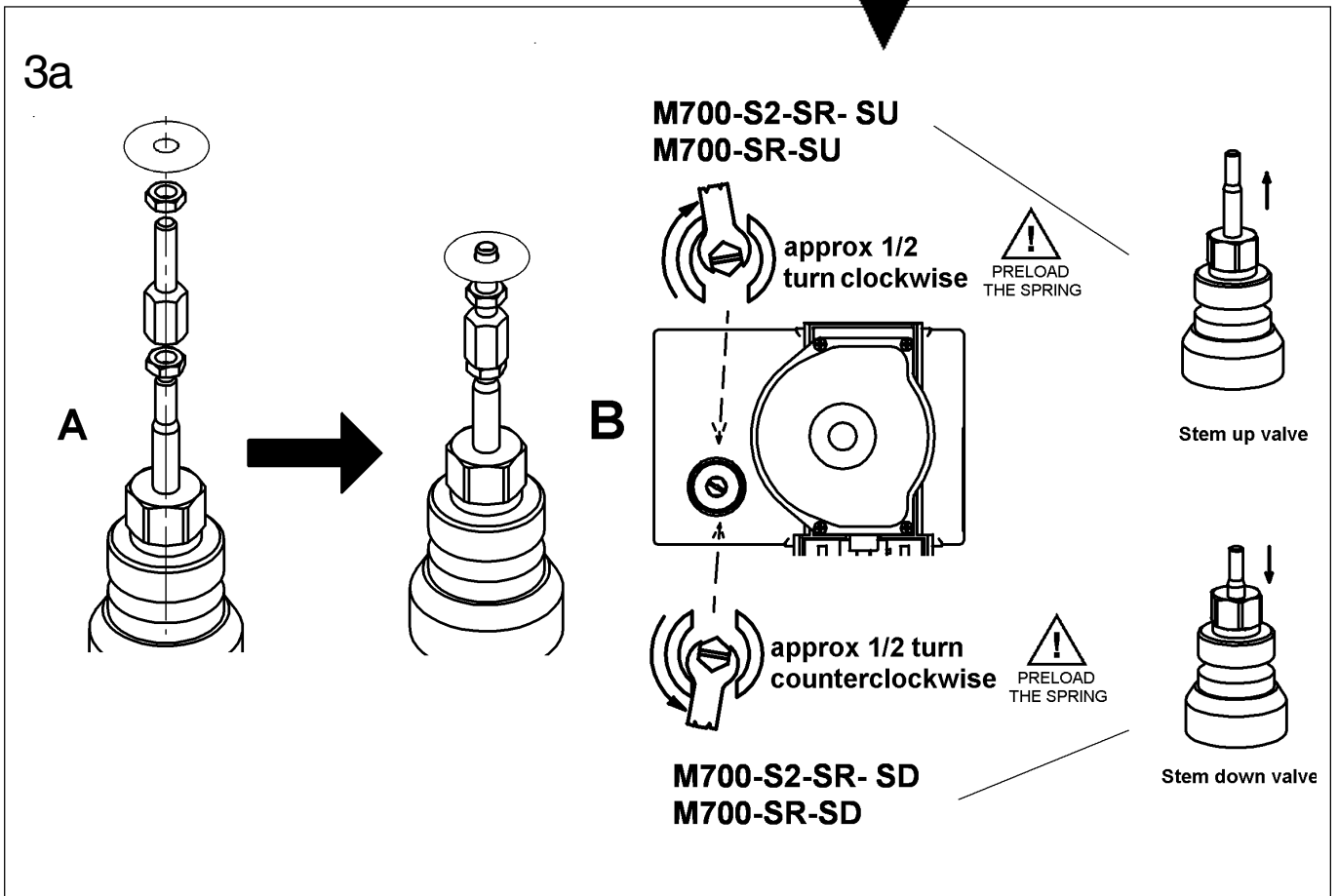

Hot media hazard. Before removing actuator from valve or opening the valve, ensure that the valve control medium is isolated and relieve the pressure. Work should only be carried out by a competent engineer.

Fara för varma media. Innan ställdonet avlägsnas från ventilen eller ventilen öppnas skall trycklöshet säkerställas över ventilen. Arbetet skall utföras av för ändamålet behörig tekniker.

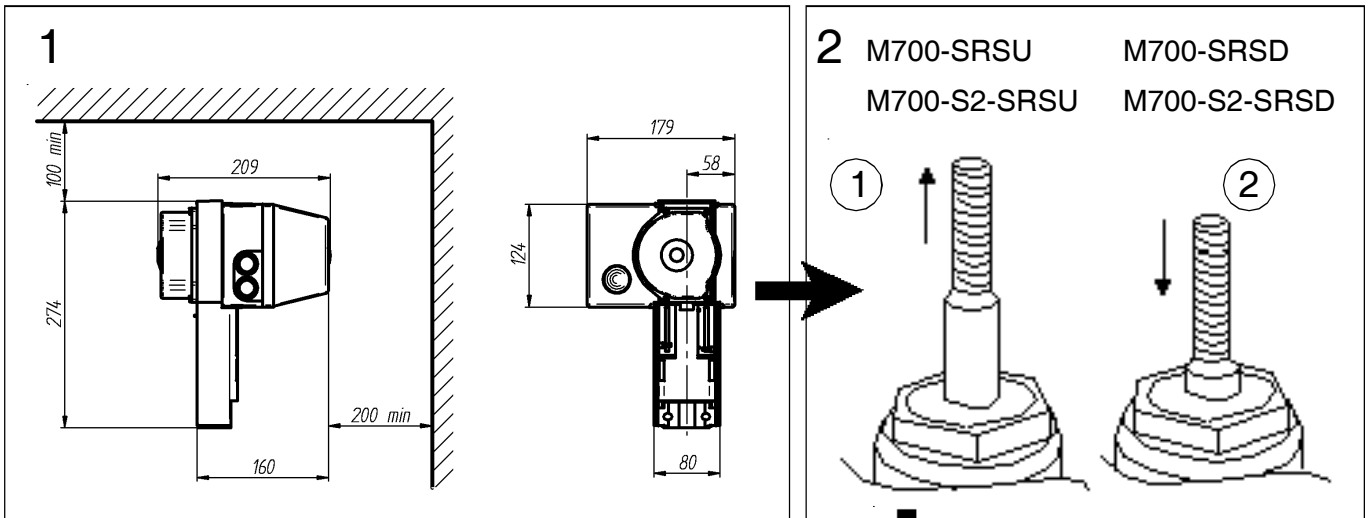

3b

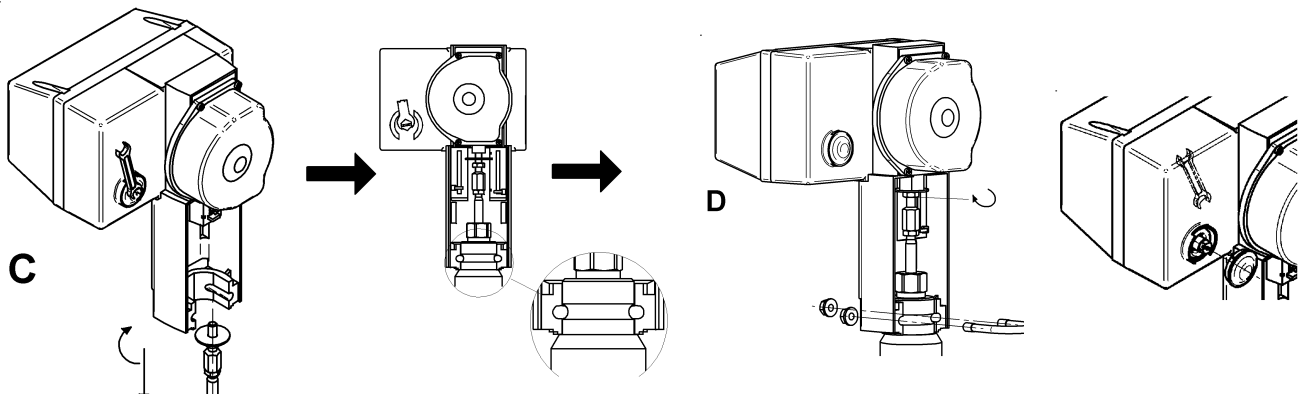

4

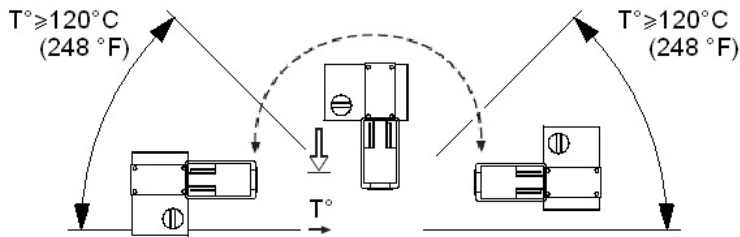

5

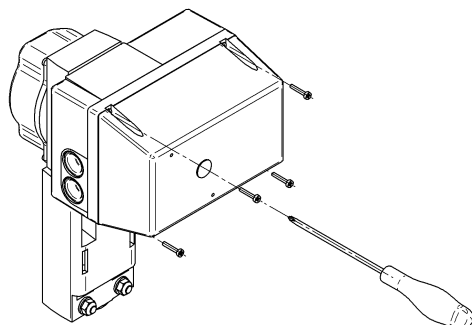

G, G0= Max 100 m (328 ft.) ..... 1.5 mm<sup>2</sup> (AWG 15)  
 X1, MX, Y, VH, VC = Max 200 m (656 ft.) ..... 0.5 mm<sup>2</sup> (AWG 20)

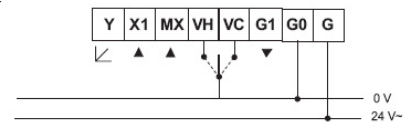
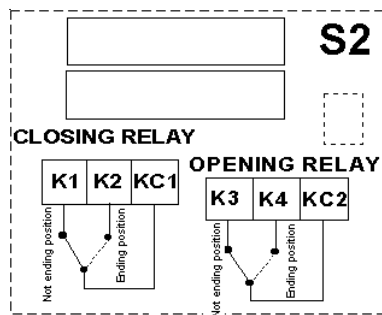

Block	Function	Description
G	24 V AC	Supply voltage
G0	24 V AC return	
X1	Input	Control signals (VH, VC short-circuited to G0)
MX	Input, neutral	
VH	Increase	
VC	Decrease	
G1	16±0.3 VDC, 25 mA	Short circuit-safe supply
Y	0-100 %	Feedback signal

6

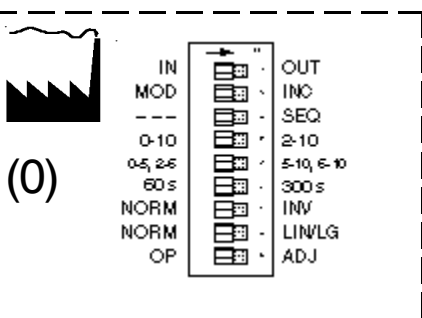

2

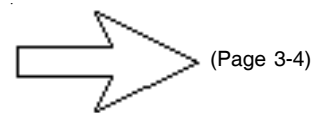
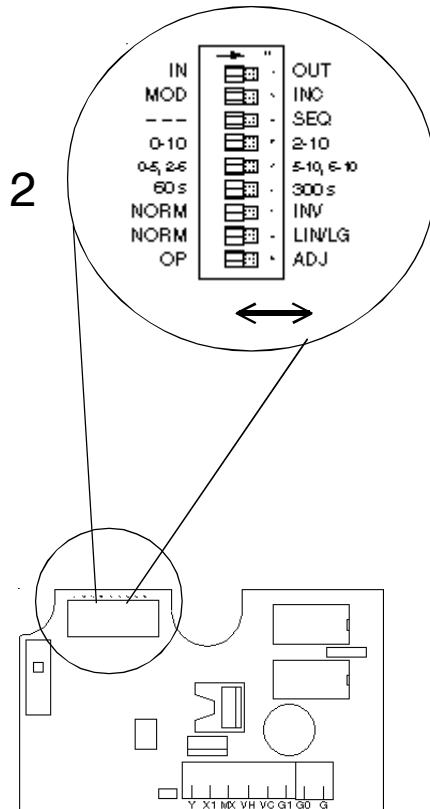

1



or

see adjustment on page 5

3

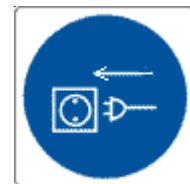

or

see adjustment on page 5

OFF



ON

<p>1</p>	<p>IN</p>	<p>OUT</p>
<p>2</p>	<p>MOD</p>	<p>INC</p>
<p>3</p>	<p>---</p>	<p>SEQ</p>
<p>4</p>	<p>0-10 (MOD)</p>	<p>2-10 (MOD)</p>
<p>5</p>	<p>0-5, 2-6 (SEQ)</p>	<p>5-10, 6-10 (SEQ)</p>
<p>6</p>	<p>60 s (INC)</p>	<p>300 s (INC)</p>
<p>7</p>	<p>NORM</p>	<p>INV</p>

(Continued ...)

(Forts.)

OFF



ON

<p>8</p>	<p>NORM</p> <p>LIN/LG</p>
<p>9</p>	<p>OP</p> <p>ADJ</p>

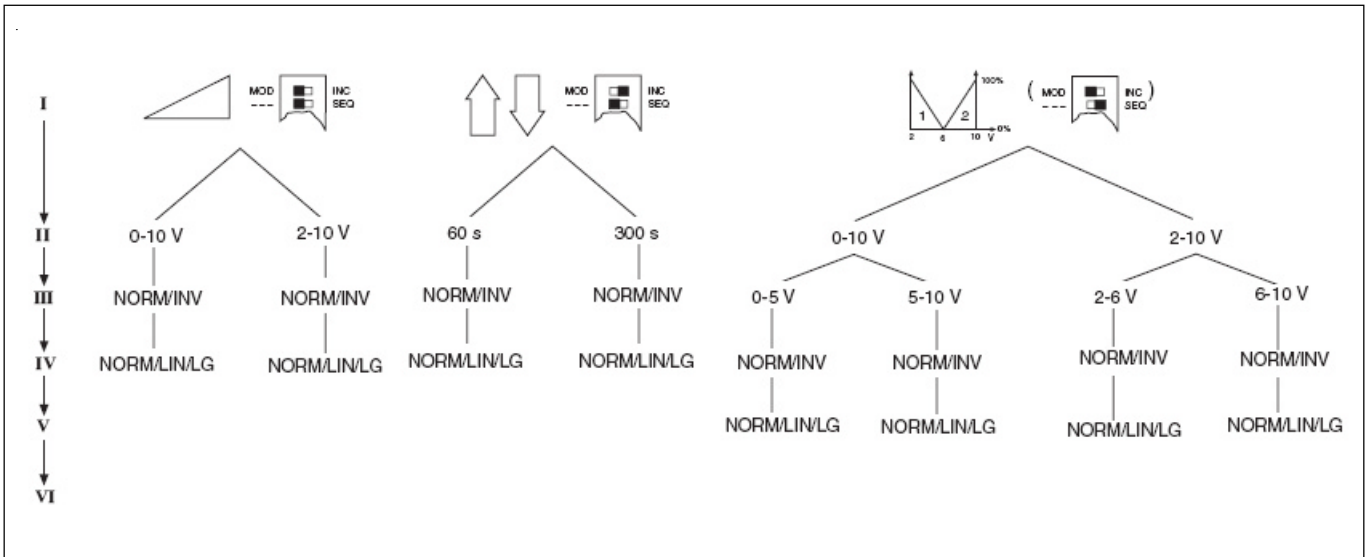

### Closing direction of the valve

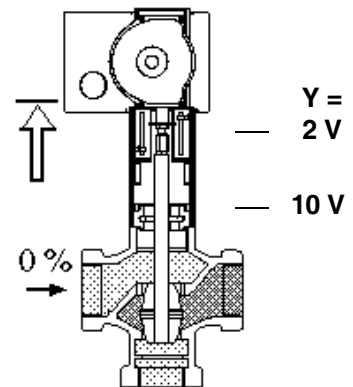
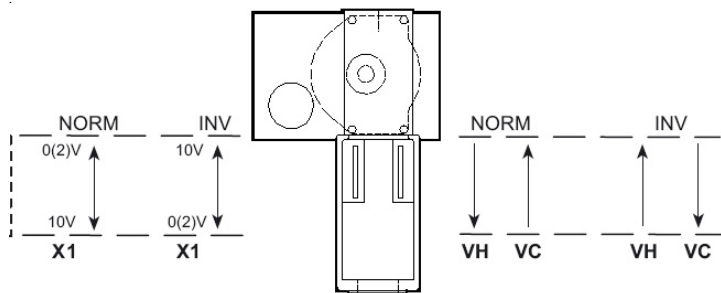

	IN	MOD	---	0-10	0-5, 2-6	60 s	NORM	NORM	OP	OUT	INC	SEQ	2-10	5-10, 6-10	300 s	INV	LIN/LG	ADJ	Function in the "OFF" pos.	"ON" position	Description
																			1 In	Out	Valve closing screw direction
																			2 Modulating	Increase/decrease	Control (not at Sequence)
																			3 -	Sequence	Sequence control
																			4 0-10 V	2-10 V	Voltage range
																			5 0-5 V, 2-6 V	5-10 V, 6-10 V	Part of voltage range
																			6 60 s	300 s	Running time
																			7 Normal	Inverted	Direction of movement
																			8 Normal	Linear/Logarithmic	Valve characteristic
																			9 Operation	End position adjust (mom.)	Operation/End position adjustment

There are nine switches in a row on the circuit board. On delivery ('Factory'), all switches are in the "OFF" position.

### 1 Valve Closing Screw Direction—IN / OUT

IN direction of movement is used when the screw of the actuator moves inwards to close the valve.

OUT direction of movement is used when the screw of the actuator moves outwards to close the valve.

### 2 Control signal—MOD / INC

TAC Forta can either be controlled by a variable direct voltage, a so called modulating signal (MOD), or by an increase/decrease signal (INC).

### 3 Sequence or parallel control— --- / SEQ

With sequence (or parallel) control (SEQ), two actuators/valves can be controlled by only one control signal.

For each of these you can choose which part of the voltage range to use, the upper one, 5-10 V (6-10 V) or the lower one, 0-5 V (2-6 V).

If the switch NORM / INV is in the NORM position, the higher voltage corresponds to 100% flow and the lower one to 0%.

With NORM / INV in the INV position you will get the opposite function.

### 4 Voltage range—0-10 / 2-10

You can choose whether to use the control signal voltage range 0-10 V or 2-10 V.

### 5 Part of voltage range—0-5, 2-6 / 5-10, 6-10

You can choose which part of a voltage range to use, the lower one 0-5 V (2-6 V) or the upper one 5-10 V (6-10 V).

If the switch is in the NORM position, the higher voltage corresponds to 100% flow and the lower one to 0%. To achieve the opposite function, the switch should be put in its INV position.

### 6 Running time—60 s / 300 s

With increase/decrease control, you can choose a running time between 60 s or 300 s.

With modulating control, the running time is always 15 s / 20 s / 30 s.

### 7 Direction of movement—NORM / INV

When normal direction of movement is used, the screw of the actuator moves inwards when the control voltage decreases or if the actuator gets a decrease signal.

With the switch NORM / INV, the direction of movement can be changed.

### 8 Linearization—NORM / LIN/LG

The motorized valve characteristics can be modified. If you wish for the characteristics to be affected, the setting LIN/LG will make the characteristics of an equally modified percentage (EQM) valve almost linear.

On the other hand, with LIN/LG a motorized valve equipped with a linear valve will operate with "Quick open characteristics". This means that with a small control signal, the valve will be almost completely open.

### 9 End position adjustment—OP / ADJ

This switch is only used to adjust the end positions when the actuator is commissioned.

Momentarily put the switch in the ON position. The actuator will automatically find the end positions of the valve.

At the end of the adjustment all the other dip switch settings (1 to 8) will be read again.

**Note!** For the actuator to register new settings of the switches, the supply voltage must be cut, the settings done and then the power on

or

the end position adjustment must be done again (see point 9).

Refer also to illustration on page 2.

(This does not apply to the switch OP/ADJ).