



M22A and M50A

G-45-10

Modulating 0 – 10 V / 0 – 20 mA
Valve Actuator for size DN 125 – DN 150

8 June 2004

M22A and M50A are electromechanical actuators for motorizing 2-way and 3-way valves large sizes DN125 and DN150 type V222, V292 and V321.

M22A and M50A actuators are powered by 24 V and controlled by 0 – 10 V DC or 0 – 20 mA signal.

M22A and M50A can be ordered mounted in factory on the valve. See data sheet F-10-6.



TECHNICAL SPECIFICATION

Part numbers see the table below
Supply voltage 24 V AC +10% / -15%, 50–60 Hz
Power consumption average 15 VA
Running time:
Modulating 0 –50 mm (0 - 2 in.)50Hz, 132 s
60Hz, 112 s
Thrust:
M22A 2200 N (495 lbf)
M50A 5000 N (1120 lbf)
Duty cycle max. 80%/60 minutes

Analog input:
Voltage 0 (2) – 10 V
Impedance 30 kOhm
Current 0 (4) – 20 mA
Impedance 125 Ohm

Ambient temperature:
Operation -20 – +70 °C (-4°F –158°F)
Storage -20 – +70 °C (-4°F –158°F)
Ambient humidity <95 %RH
Enclosure rating IP 65

Standards:
Emission EN 50081-1: 03.1993
Immunity EN 50082-1: 11.1997
EN 50082-2: 02.1996

Material:
Housing CoPA - Grivory GV-4H
Cover PC - Polycarbonat
Color black/blow

Weight:
M22A 5,4 kg (11,9 lb.)
M50A 6,0 kg (13,2 lb.)

Dimensions mm (in)

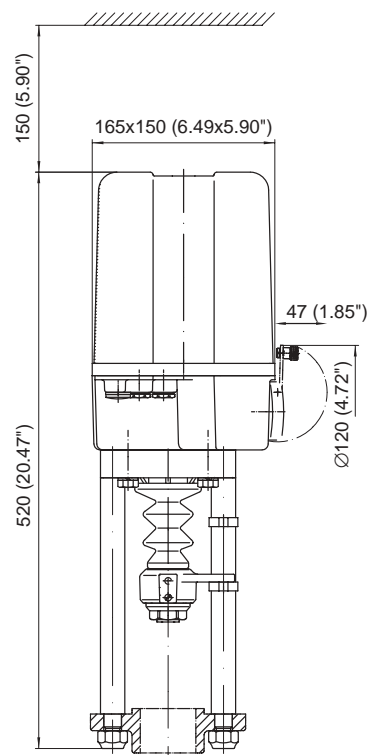

Part number	Description	Power supply	Power consumption	
			50 Hz	60Hz
890-0104-000	M22A-24V	24 Vac+10%/ -15%	12 VA	15 VA
890-0204-000	M50A-24V	24 Vac+10%/ -15%	12 VA	15 VA

FUNCTION

The actuator

M22A and M50A consists of a reversible motor and a gear train in a CoPA housing.

All bearings of motor and gear train are of permanent lubrication type.

The reversible motor cuts out in both end positions on activating limit switches.

Control signal

M22A and M50A are controlled by a voltage input so that a certain level always corresponds to a position of the actuator. This is done by the Electronic Positioner ES11.

The control signal reaction can be set by switch normal or inverted.

Manual operation

The actuator can be manually operated by means of a hand wheel. Since the hand wheel always follows during motor-driven operation (running indication), never operate by hand while the actuator is running – potential injury hazards

Note: Switch of the electrical source and secure against turning on again.

The position of the actuator is indicated with a pointer between the actuator and the valve.

WIRING

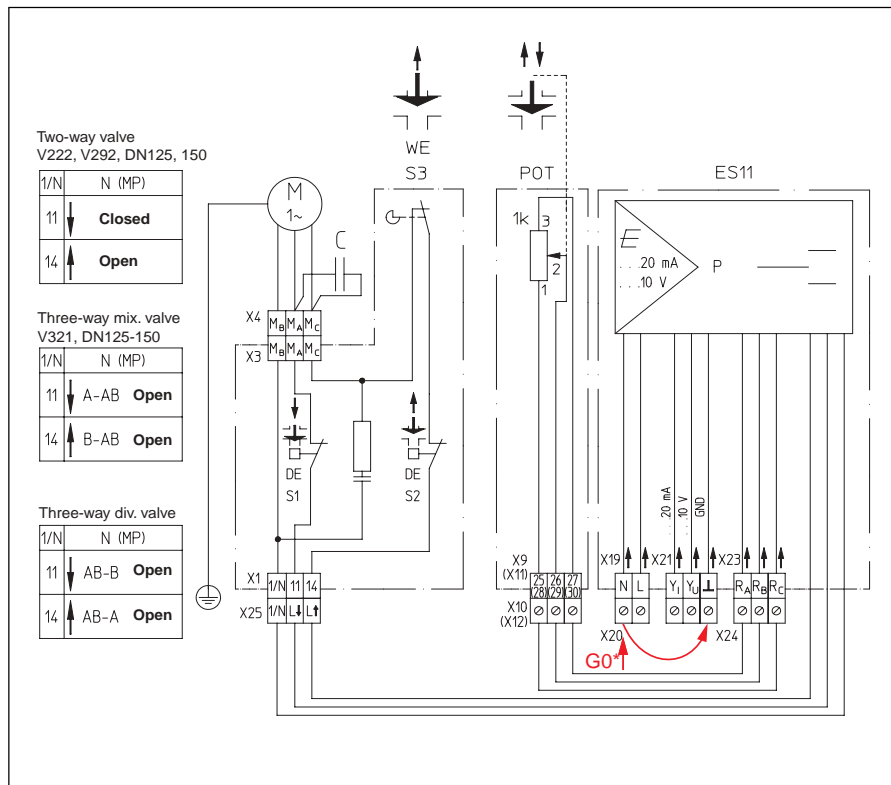

INSTALLATION

The installation of the M22A and M50A is carried out according to instruction, shipped together with the actuator, if the actuator is mounted on the valve from factory.

How to mount and adjust a M22A and M50A actuator to a valve is described in the handbook for M22 and M50.

The actuator may be mounted beside or above the valve. Mounting below the valve should be avoided.

Trademarks and registered trademarks are the property of their respective owners.

TAC Vista®, TAC Menta®, TAC Xenta® and TAC I-talk® are registered trademarks of TAC AB. LonMark® and LonWorks® are registered trademarks of the Echelon Corporation. Windows® is a registered trademark of Microsoft.