



2 STAGES ROOM THERMOSTATS FOR FAN COIL

DB-TA-3C3..9

FUNCTION

Temperature control in heating, refrigeration and air conditioning for typically fan coil systems with 2 stages.

- 2 relay outputs;
- manual selection of On/Off, 3 fan speeds (depending on model);
- internal or remote temperature sensor (optional).

The thermostat is provided with a LCD display and keys +/- for parameters setting like the range, the type of action (direct or

reverse), the differential between the stages and the differential in the stages. In normal condition of use the temperature is visualized with a step of 0.1°C. The voltage free On/Off switch connected together the 3 fan speeds switch allows to power on and off the fan. On request it is possible to have a version with economy function by a remote contact. When the contact is closed the thermostat works in economy mode.

| TYPE | ON/OFF | 3- SPEED | DIFFERENTIAL/HYSTERESIS K |
|---------------|--------|----------|---------------------------|
| DB-TA-3C3-139 | • | • | 0.5...4 |
| DB-TA-3C3-199 | • | | 0.5...4 |
| DB-TA-3C3-939 | | • | 0.5...4 |
| DB-TA-3C3-999 | | | 0.5...4 |

On request:

optional remote 1 m cable sensor, selectable by jumper; ordering code: NTA010-623.

TECHNICAL FEATURES

Power supply: 230 Vac \pm 10 %, 50/60 Hz
Outputs: valves: 2 relays SPDT 230 Vac 6 A
 speeds: 230 Vac 6 A
Power cons.: 1 W
Sensor: NTC 10K
Range: +5...+30 °C
Hysteresis between stages: 0.5...4 K
Hysteresis in stages: 0.5...4 K
Display: resolution 0.1 °C
Working: 0...+40 °C
 10...90% r.h. (non condensing)
Storage: -20...+70 °C
 < 95 % r.h.
Housing: ABS self-extinguished according to UL94 V-0 color (RAL 9010)
Protection class: IP30, class II
Size: 144 x 82 x 34 mm
Weight: 220 g

ELECTRICAL WIRING

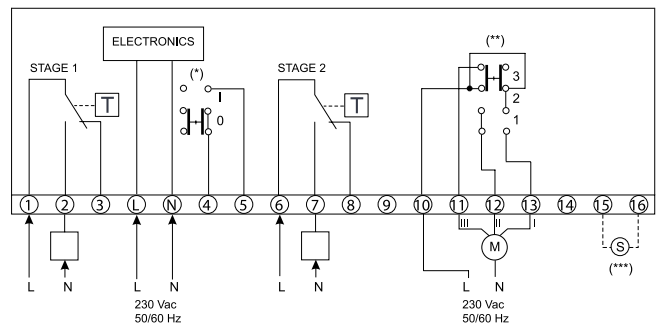

- (*) only for models DB-TA-3C3-139, DB-TA-3C3-199
- (**) only for models DB-TA-3C3-139, DB-TA-3C3-939
- (***) remote sensor (optional)

Logic of relay outputs

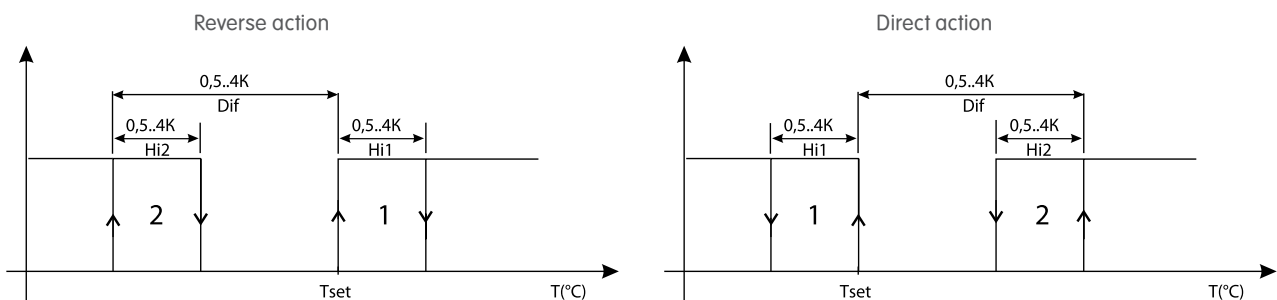

DiF temperature difference between activation of stage 1 and 2
Hi1 hysteresis stage 1
Hi2 hysteresis stage 2

