



ROOM CONTROLLERS FOR 2- OR 4- PIPE FAN COILS

DBTA-393

FUNCTION

2- pipe fan coil with 3- speed motor fan control for room temperature applications with:

- manual selection of thermostatic fan/continuous fan/Off,
- 3 motor speed and season change over;

- room temperature visualisation with display;
- setpoint selection by step of 0.5 °C on display;
- internal or remote temperature sensor (optional).

TYPE	VT/VC/OFF	3- SPEED	LOCAL S/W
DBTA-393-433	•	•	•

On request:

optional remote 1 m cable sensor, selectable by jumper; ordering code: NTA010-623.

TECHNICAL FEATURES

Power supply: 230 Vac ± 10%, 50/60 Hz
Max load: 6 A
Output: 1 relay SPDT 230 Vac 6 A
Power cons.: 1 W
Sensor: NTC 10K
Range: 0...+40 °C
Setpoint: +5...+30 °C
 adjustment by step of 0.5 °C.
Differential: 0.5 °C
Display: resolution 0.1 °C
Working: 0...+40 °C
 10...90% r.h. (non condensing)
Storage: -20...+70 °C
 < 95 % r.h.
Housing: ABS self-extinguished according to UL94 V-0
 color (RAL 9010)
Protection: IP30, class II
Size: 144 x 82 x 27 mm
Weight: 220 g

Terminal connections for 4- pipe air conditioning and heating systems.

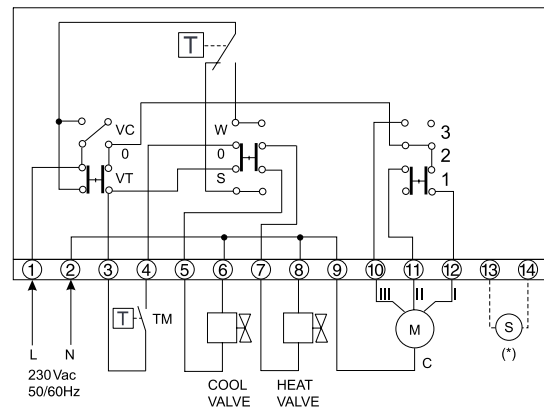

ELECTRICAL WIRING

Terminal connections for 2-pipe air conditioning and heating systems.

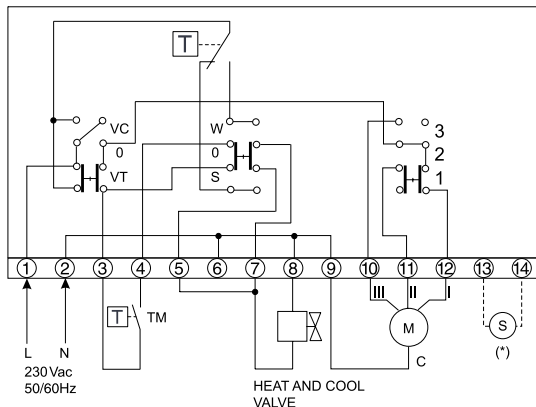

- (*) optional remote sensor
- TM minimum thermostat

Jumper setting:

- J1 closed = internal sensor
- J1 opened = remote sensor

The products are factory supplied with internal sensor.

