

Part number	Stroking time (s)		Torque Nm (2)	Power supply	Control
	90 (1)	160			
MDL22	15	27	6 (8)	230 V~	3 p
MDL24	45	80	20 (27)	230 V~	3 p
MDL26	60	107	30 (40)	230 V~	3 p
MDL62	15	27	6 (8)	110 V~	3 p
MDL64	45	80	20 (27)	110 V~	3 p
MDL66	60	107	30 (40)	110 V~	3 p
MDL42	15	27	6 (8)	24 V~	3 p
MDL44	45	80	20 (27)	24 V~	3 p
MDL46	60	107	30 (40)	24 V~	3 p
MDL32	15	27	6 (8)	24 V~	pot. (3)
MDL34	45	80	20 (27)	24 V~	pot. (3)
MDL36	60	107	30 (40)	24 V~	pot. (3)
MDL52	15	27	6 (8)	24 V~	prop. (4)
MDL54	45	80	20 (27)	24 V~	prop. (4)
MDL56	60	107	30 (40)	24 V~	prop. (4)

- (1) Factory setting.
- (2) The values in brackets indicate the starting torque.
- (3) Models that may be set for voltage or current proportional control, using the options described further.
- (4) Fixed-range proportional models. This version is physically obtained by including the MDLS5 module in the MDL3 series actuator.

APPLICATIONS AND USE

MDL actuators are used in civil and industrial systems for driving dampers and other devices, which require the control of an angular position within a max. angle of 160° (e.g. for adjusting the flame in liquid or gas burners).

MDL actuators are equipped with a double shaft output; their size is such that they are interchangeable with other qualified manufacturers' actuators. Using the appropriate bracket, they are also interchangeable with Controlli SL old-model actuators. MDL actuators can be installed in any position.

Each actuator is available in three basic model types:

- Floating (3p)
- Proportional potentiometric (pot.)
- Proportional voltage or current, with fixed ranges (prop.)

By means of easily mountable additional modules, the models with proportional potentiometric control may be voltage or current controlled in the following versions:

- Selectable fixed ranges; see MDLS5 option
- Variable range start and slope, see MDLV5 option



OPERATION

All models are equipped with a permanent magnet synchronous motor, which makes stroke time independent from load, and increases reliability, avoiding the use of mechanical brake. The stroke angle of the actuator can be adjusted easily by means of graduated cam disks fitted internally. On the outside is located a disk that indicates the angular position of the shaft.

All 24 V~ models have an electrical device for the manual control in both directions of the actuator in case of absence of control signal or of failure of the electronic card.

The electric manual control can also be remote, according to the wiring diagram illustrated in fig. 5.

It is available an internal mechanism for unlocking the main shaft; this mechanism permits the shaft to rotate freely in both directions, simplifying assembly operations and cam calibration.

In the models with floating control is available, as an optional accessory, an auxiliary potentiometer (its card is preset for mounting 1 additional potentiometer, on request). In the models with proportional control it is also available an output signal depending on the angular position of the shaft, and a device for reversing the direction of rotation.

The rotation directions are defined as “clockwise” or “counterclockwise”, in respect with the position indicator side.

MANUFACTURING CHARACTERISTICS

The actuator does not require any maintenance. It consists of an aluminium die-cast case and upper cover in thermoplastic material.

Holes for installation are provided both on the base and on the front.

The reduction gear has output shaft supported by self-lubricating bushings. The electronic card is fitted on top, it can be reached by removing the cover, also providing an easy access to the terminals for wiring connections.

TECHNICAL CHARACTERISTICS

Power supply	24-110-230 V~ ±10.%
Consumption	11 VA (17 VA for 230 V~)
Dimensioning	15 VA (20 VA for 230 V~)
Frequency	50 ... 60Hz
Rotation angle	MDL3./5.: preset at 90° selectable for 160° adjustable between 55 and 160° MDL2./4./6.: preset at 90° adjustable between 0 and 160°
Stroke time	See available models (values referred to 50Hz; if frequency is 60Hz, the stroke time is lower than 20%)
Nominal torque	See available models
Starting torque	See available models
Radial force on shaft outputs	500 N max.
Temperature	
working	-15T 55
storage	-50T 60
Ambient humidity	R class (DIN 40040)
Terminal board (*)	screw-type, for 1.5 to 2.5 mm ² wires
Two cable sleeves	Rubber, with membrane punchable on D=16 mm hole; to be replaced by PG 13.5 compression glands IP 55 DIN 40050 (IEC 529)
Protection degree	For environment with normal pollution according to IEC730-1 (93)/6.5.3 any
Installation position	any
Weight	2.6 kg
Control signal	
3 position control	2 SPST contact
Proportional control	
- potentiometric	165 ohm
- with MDLS5 module	
in voltage	4...7V/6...9V/8...11V/0...10V
in current	4...20 mA
- with MDLV5 module	
variable range start	0...15 V or mA
variable range width	3...16 V or mA
Remark: for all models:	
voltage ranges	0.1 mA max
current ranges	250 ohm
Indication outputs (for MDL3./5. only)	
in voltage	0...10 V- (2 mA max.) 10...0 V- (2 mA max.)
in current	0...200 µa

The output signal is perfectly calibrated for a 90° stroke. For 160° stroke, a deviation of the output signal at the stroke end (negative tolerance) may occur.

Product in compliance with EMC89/336 directive according to the below-mentioned standards:
- EN50081-1 for emission - EN50082-1 for immunity

POSSIBLE COMBINATIONS AND CONNECTIONS

All actuator models can be connected to any controller having control signal corresponding to the indications given in the "Technical Characteristics" paragraph. In particular, they can be connected to CONTROLLI 500 Line, DIGITROLL 4000, 5000, 7000, Line 200 and 300 controllers.

ACCESSORIES AND OPTIONS

Model	Description
DMDL	Two auxiliary microswitches (SPDT 10(3)A 250 V) adjustable on the whole stroke. Micro-disconnection type 1B according to IEC730-1(93)/6.4.3.2
MDLA1	Damper operating lever (adjustable arm 43...74 mm)
YS7	Damper control device (in addition to the MDLA1 lever) consisting of: articulated joints, steel connecting rod Ø 8 mm - length 500 mm, lever for damper shaft, Ø 12, adjustable (43...74 mm).
MDLA2	Bracket for interchangeability between MDL and SL
MDLPA2	for MDL2 electronic cards with
MDLPA4	for MDL4 1 KOhm auxiliary
MDLPA6	for MDL6 potentiometer (1)

(L) On request it is possible to assembly 1 potentiometer.

AF22	Coupling for VF butterfly valves.
MDLS5	Module for current control signal 4...20mA or voltage control signal, with selectable fixed ranges 4...7V/6...9V/8...11V/0...10V.
MDLV5	Module for current or voltage control signal, variable as regards the start and the slope of the range.

INSTALLATION AND MOUNTING

The actuator can be installed in any position. Electrical connections are carried out by removing the cover and must conform to existing rules.

The actuator is set for a 90° angular stroke. To set different strokes it is necessary to adjust the cams using the supplied spanner, inserting it into the slot near the aux. cams.

On MDL3./5. models there is a jumper to enable stroke selection (90°/160°/VAR). Positions 90° and 160° refer to fixed strokes, while by selecting VAR it is possible to set variable strokes (between a minimum of 55° and a maximum of 160°) using the P1 trimmer (see fig. 1).

The actuator is supplied with the shaft positioned on the 0 of the external position indicator (see fig. 2). To simplify installation and cam calibration at the angular ends:

- using a screwdriver, unlock the main shaft, by rotating 180° counterclockwise the loosening pivot located on the board
- put the main shaft in the desired position by operating on the square extremity
- position the cams at due angulation
- reposition the main shaft on 0 of the outside position indicator and lock it by turning clockwise the pivot.

WARNING: The shaft unlocking mechanism must never be operated under load.

On all 24 V~ models, in order to control manually the actuator, move CM1 changeover switch to MANual position and act on SW7 switch to control the actuator in both directions.

In the MDL3./5. models, to reverse direction in respect with control operate on jumper SW3.

To obtain a remote manual control, besides moving the CM1 changeover switch in MAN position, it is necessary to use the additional terminals 1, 2 and 3, carrying out the wiring according to fig. 5. As regards the operations to be performed during assembly, see the detailed description given in the mounting instructions supplied in the package.

MDLS5 Option

The MDLS5 module is preset for 0...10 V control signal. To select different ranges, move the SW1 jumper from the preset position to the desired one (see fig. 3).

For the 4...20 mA range it is also necessary to position on SW1 the jumper set in JMP position.

MDLV5 Option

The MDLV5 option is preset for voltage control signal.
 To select the current range it is necessary to move the two jumpers preset in JMP position to SW1 position and to act on P2 and P3 trimmers to define the start and slope of the required range (see fig. 4).

OPTIONAL MODULES

ELECTRONIC CARD

only for MDL3./5.

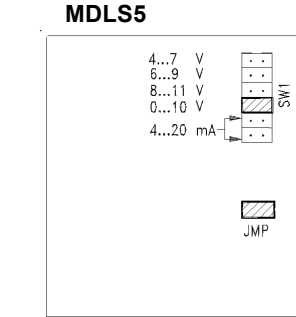

N3028F1

FIG.3

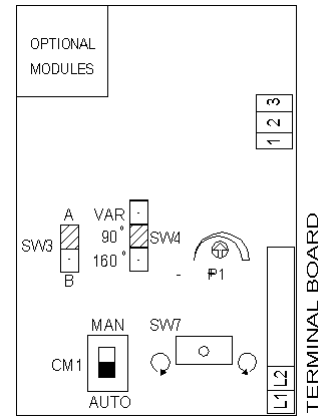

N3030

FIG. 1

LIMIT OF SHAFT ANGULAR ROTATION
 (stroke 90° = factory setting)

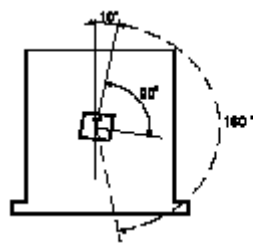

Power side view

N3029F2

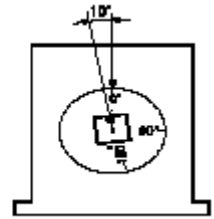

Position indicator side view

N3029F1

FIG. 2

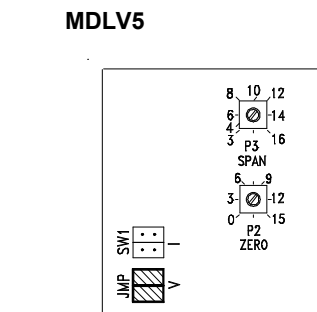

N3028F1

FIG.4

REMOTE MANUAL CONTROL WIRING DIAGRAM (MDL3./5.)

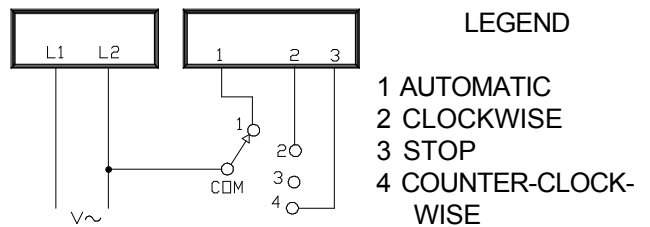

N3027

FIG.5

Note: CM1 electronic board changeover switch has to be moved on MAN position.

TERMINAL BOARDS
MDL 2./4./6. (4)

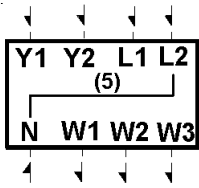

N3009

LEGEND

L1	Power supply	
L2		
Y1	Clockwise	Control
N	Common	
Y2	Counter-clockwise	
W1		Potentiometer
W2	Central	
W3		

MDL3./5.

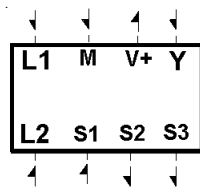

L1	Power supply	
L2		
M	Common	(1)
V+	Output +15 V-	
Y	Control signal (2)	
S1	Analogical common	(3)
S2	0...10V or 0...200 uA	
S3	10..0V- or 200..0 uA	

LEGEND

- (1) For the MDL3. model, connect the central of the controller's potentiometer (165 ohm) to Y terminal, a side connector to M terminal and the other to the V+ terminal.
- (2) With jumper SW3 in A position, looking at the actuator from the power side, for increasing control signal, the shaft moves clockwise.
- (3) Connect the eventual indicator with current input to terminals S3 (or S2) and S1 (max 200 uA). Connect the eventual indicator with voltage input to terminal S3 (or S2) and M (max 2 mA). The value of voltage (current) on extreme left corresponds to shaft in position 0°.
- (4) The MDL2./4./6. actuator is supplied with L1 and L2 jumpered. The power supply to the actuator is given by the controller through the control signal (between N-Y1 for clockwise rotation or N-Y2 for counter-clockwise rotation). Manual control: available only on MDL4 actuator. To enable such control, remove the jumper between L1 and L2 and connect them to power supply. In this case the controller signal must come from potential-free contacts (dry contacts) connected between N-Y1 or N-Y2.
- (5) Internally connected.

OVERALL DIMENSIONS (mm)

MDLACTUATOR

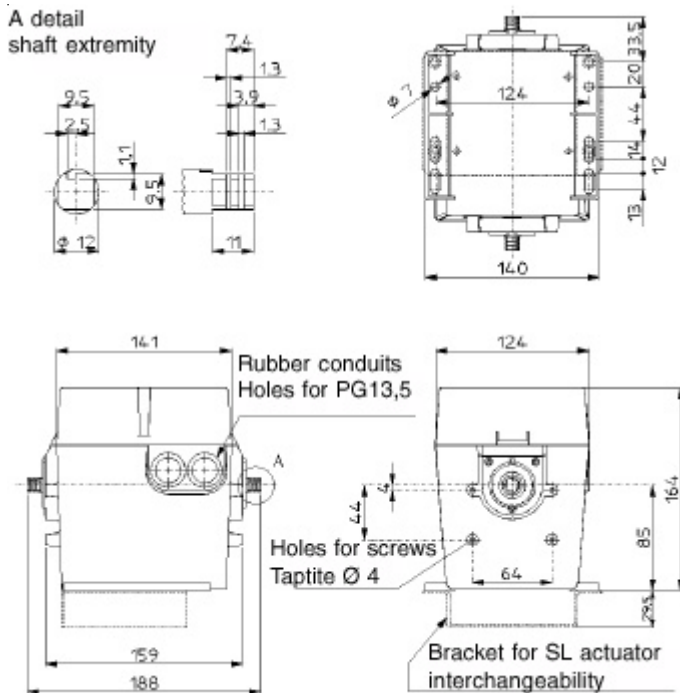

N4027

DAMPER OPERATING LEVER (MDLA1)

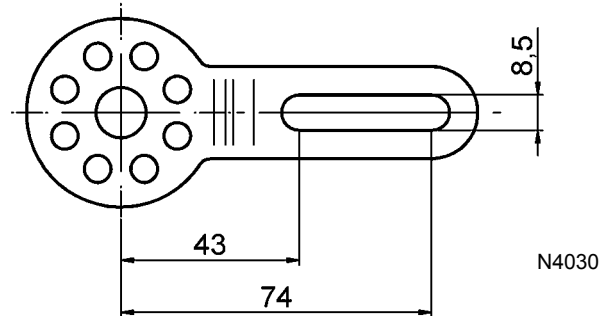

N4030

DAMPER CONTROL DEVICE (YS7)

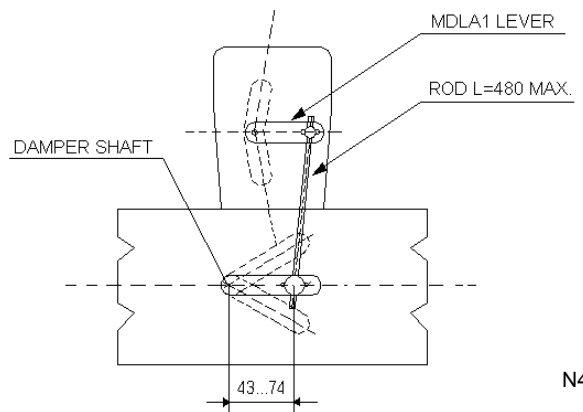

N4031

The performances stated on this sheet can be modified without prior notice due to design improvements.